

WARRANTY REGISTRATION FORMS AND PROCEDURES

Liberty Pull-Type

WARRANTY REGISTRATION & DEALER INSPECTION FORM

The following section contains the necessary documents used to register a new BBI unit for warranty. In order to activate the new equipment warranty, these forms should be returned to BBI no later than 30 (thirty) days from the date of sale to the end user.

These forms are in triplicate and distributed as follows:

1. Dealer retains one set for his / her records
2. One set returned to BBI
3. One set remains in operator's manual and given to end user at time of delivery

These documents are as follows:

Dealer Inspection Form

This form is completed when the dealer is preparing to deliver the new unit to the end user. It certifies the dealer has inspected the equipment, it operates correctly and all safety signs and guards are in place. Any modifications made to the equipment by the dealer should also be noted.

Customer's Warranty Registration

This form certifies that the customer was instructed on safe and proper use, the equipment operates correctly, warranty was explained and a copy of the owner's manual was delivered. This form also certifies that if electronic rate control is installed, the customer has been given proper instruction as to the operation of the system. Furthermore, a dealer service contact name and number has been provided.

Important Tractor-Supplied Hydraulic Systems Information

This form certifies that if the unit is equipped with Tractor Supplied Hydraulics, proper return requirements were discussed.

**Please return the executed copies to BBI within 30 days to activate the warranty.
The copies can be sent via email to: service@bbispreaders.com, faxed to: 706-778-2787,
or mailed to: BBI Spreaders P.O. Box 630 Cornelia, GA 30531.**



DELIVERY INSPECTION - DEALER COPY

Liberty Pull-Type

WARRANTY REGISTRATION & DEALER INSPECTION FORM

To have a fully-executed warranty, the dealer must fill this form out at time of delivery. There is no warranty without a fully-executed warranty registration and dealer inspection form.

Model & Serial Number: _____

DEALER EQUIPMENT AND SAFETY INSPECTION REPORT

- Equipment is properly assembled
- Equipment configured as ordered
- Equipment is functional and operates properly
- All guards are in place
- All warning signs and safety signs are in place
- Modifications to equipment (write details below)

Comments / equipment modifications: _____

Signature of Set-Up Person

Dealer Name

Date



CUSTOMER'S WARRANTY REGISTRATION - DEALER COPY

Liberty Pull-Type

Dealer name: _____	Customer name: _____
Address: _____	Address: _____
_____	_____
City, State, Zip: _____	City, State, Zip: _____
_____	_____
Date of Delivery: _____	Phone #: _____
Model & Serial Number: _____	Email Address: _____
_____	_____

CUSTOMER'S WARRANTY REGISTRATION

Customer's warranty protection on this equipment is only valid when this certification form is completed and signed by both the customer and dealer at the time of delivery of the equipment and registered with the manufacturer.

DEALER'S SIGNATURE INDICATES:

<input type="checkbox"/> Equipment operates properly and customer was instructed in safe and proper operation
<input type="checkbox"/> Customer received a copy of the operator's manual
<input type="checkbox"/> Warranty was explained to the customer
<input type="checkbox"/> Electronic Rate control programmed and operates correctly

Signature of Dealer

Dealer Name

Date

CUSTOMER'S SIGNATURE INDICATES:

<input type="checkbox"/> Acceptance of equipment
<input type="checkbox"/> Receipt of owners manual and clear understanding of warranty
<input type="checkbox"/> All systems were explained and understood
<input type="checkbox"/> Receipt of instructions on safe and proper use
<input type="checkbox"/> If equipped with Electronic Rate control, this system was explained and owners manual was received
<input type="checkbox"/> A dealer parts/service representative contact has been provided (see page 28)

Signature of Customer

Customer Name

Date



TRACTOR-SUPPLIED HYDRAULICS - DEALER COPY

Liberty Pull-Type

IMPORTANT TRACTOR-SUPPLIED HYDRAULIC SYSTEMS INFORMATION

IMPORTANT!



On units equipped with tractor-supplied hydraulics the return must be connected to a 0 (zero) pressure return. Gear motor systems require no pressure return.

DO NOT connect the system unless 0 (zero) pressure can be verified on return or damage to the motors will result! Connecting to a pressurized return will VOID THE WARRANTY.

Various tractor manufacturers use different language for their brand to identify a 0 (zero) pressure return. Please consult your manufacturer to insure the proper 0 (zero) pressure return is identified.

To maintain maximum operational efficiency, your tractor needs to have 21 GPM (Gallons Per Minute) overall and 2,000 PSI (Pounds per Square Inch) in order to operate the hydraulic spinner system. Lesser flow and pressure will deteriorate maximum performance.

Signature of Dealer

Dealer Name

Date

Signature of Customer

Customer Name

Date

DEALER INSPECTION - BBI COPY

Liberty Pull-Type

WARRANTY REGISTRATION & DEALER INSPECTION FORM

To have a fully-executed warranty, the dealer must fill this form out at time of delivery. There is no warranty without a fully-executed warranty registration and dealer inspection form.

Model & Serial Number: _____

DEALER EQUIPMENT AND SAFETY INSPECTION REPORT

- Equipment is properly assembled
- Equipment configured as ordered
- Equipment is functional and operates properly
- All guards are in place
- All warning signs and safety signs are in place
- Modifications to equipment (write details below)

Comments / equipment modifications: _____

Signature of Set-Up Person

Dealer Name

Date



CUSTOMER'S WARRANTY REGISTRATION - **BBI COPY**

Liberty Pull-Type

Dealer name: _____	Customer name: _____
Address: _____	Address: _____
_____	_____
City, State, Zip: _____	City, State, Zip: _____
_____	_____
Date of Delivery: _____	Phone #: _____
Model & Serial Number: _____	Email Address: _____
_____	_____

CUSTOMER'S WARRANTY REGISTRATION

Customer's warranty protection on this equipment is only valid when this certification form is completed and signed by both the customer and dealer at the time of delivery of the equipment and registered with the manufacturer.

DEALER'S SIGNATURE INDICATES:

<input type="checkbox"/> Equipment operates properly and customer was instructed in safe and proper operation
<input type="checkbox"/> Customer received a copy of the operator's manual
<input type="checkbox"/> Warranty was explained to the customer
<input type="checkbox"/> Electronic Rate control programmed and operates correctly

Signature of Dealer

Dealer Name

Date

CUSTOMER'S SIGNATURE INDICATES:

<input type="checkbox"/> Acceptance of equipment
<input type="checkbox"/> Receipt of owners manual and clear understanding of warranty
<input type="checkbox"/> All systems were explained and understood
<input type="checkbox"/> Receipt of instructions on safe and proper use
<input type="checkbox"/> If equipped with Electronic Rate control, this system was explained and owners manual was received
<input type="checkbox"/> A dealer parts/service representative contact has been provided (see page 28)

Signature of Customer

Customer Name

Date



TRACTOR-SUPPLIED HYDRAULICS - **BBI COPY**

Liberty Pull-Type

IMPORTANT TRACTOR-SUPPLIED HYDRAULIC SYSTEMS INFORMATION

IMPORTANT!



On units equipped with tractor-supplied hydraulics the return must be connected to a 0 (zero) pressure return. Gear motor systems require no pressure return.

DO NOT connect the system unless 0 (zero) pressure can be verified on return or damage to the motors will result! Connecting to a pressurized return will **VOID THE WARRANTY**.

Various tractor manufacturers use different language for their brand to identify a 0 (zero) pressure return. Please consult your manufacturer to insure the proper 0 (zero) pressure return is identified.

To maintain maximum operational efficiency, your tractor needs to have 21 GPM (Gallons Per Minute) overall and 2,000 PSI (Pounds per Square Inch) in order to operate the hydraulic spinner system. Lesser flow and pressure will deteriorate maximum performance.

Signature of Dealer

Dealer Name

Date

Signature of Customer

Customer Name

Date

SALFORD **BBI** **LIBERTY**

OPERATOR MANUAL

This manual is valid for Liberty Pull-Type configurations

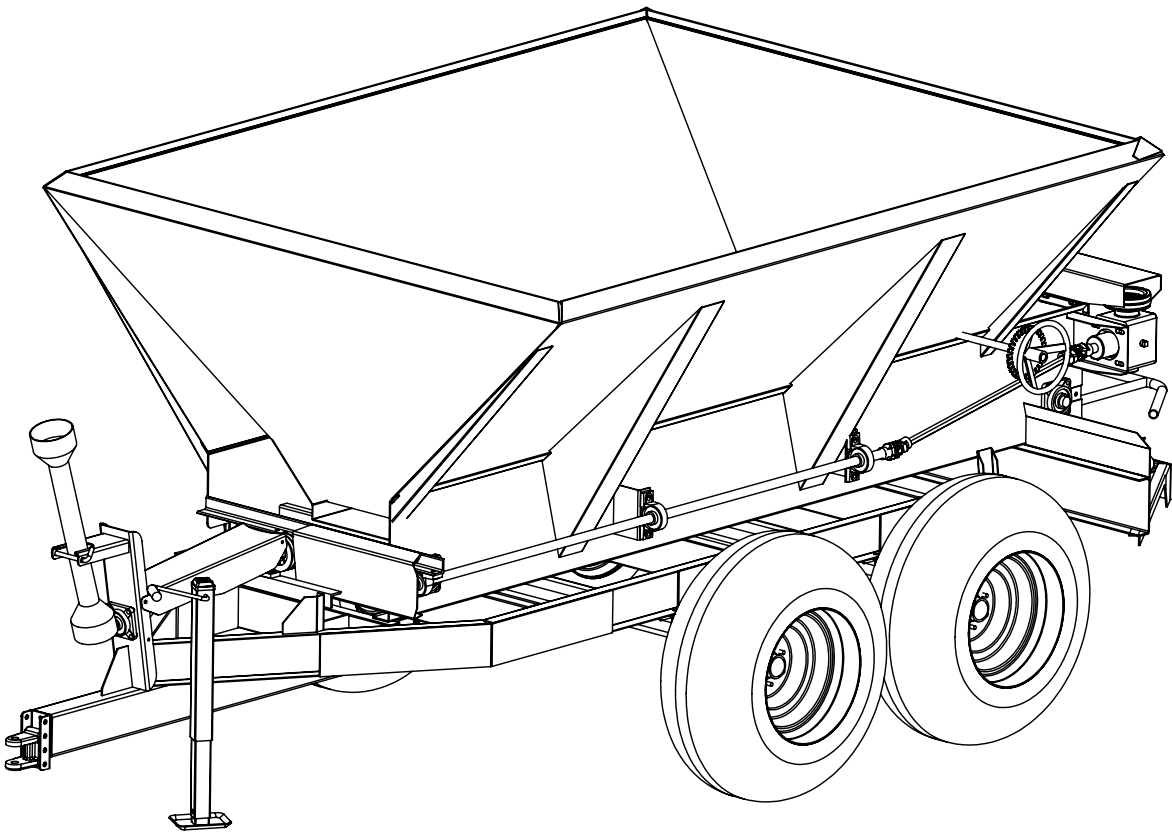

TABLE OF CONTENTS

Liberty Pull-Type

2	TABLE OF CONTENTS
3	A MESSAGE FROM BBI
4-6	DELIVERY AND WARRANTY CHECKLISTS
7	WARRANTY
8-10	SAFETY INSTRUCTIONS
11	TRACTOR PREPARATION AND HOOK-UP
12	HYDRAULIC CONFIGURATION
13-17	IDENTIFYING COMPONENTS
18-21	FIELD TESTING
22-23	MACHINE OPERATION
24-28	LUBRICATION AND MAINTENANCE
29	TIPS & TRICKS
30	PARTS AND SHIPPING
31	PARTS IDENTIFICATION AND ORDERING
32-48	ASSEMBLY AND PARTS IDENTIFICATION
49-54	GROUND SPEED TABLES AND RATE CHARTS

A MESSAGE FROM BBI

The BBI team takes pride in producing superior spreaders that will provide many years of service. In bringing the best spreaders to the industries of agriculture, poultry, and construction, we carefully select components with a proven performance record and availability. Our skilled employees give special attention to detail in design and assembly to make certain our equipment will meet or exceed your expectations in the field.

Our parts department stands ready to serve you with replacement parts at affordable prices. We stock a large inventory to assure support for our customers, and take pride in offering “same day service” for those orders received before mid-afternoon.

At BBI, we provide quality service with a friendly atmosphere. Our dealers can offer service assistance, or you may contact us directly. We strive to quickly provide solutions for your needs in order to minimize any downtime or delays.

Our company takes safety very seriously, and we give great concern to our products in an ongoing effort to reduce any potential safety issues, whether with equipment or in the workplace. We design our equipment intentionally to minimize pinch points and provide guards where they do exist. BBI places decals on our equipment to identify and caution against areas containing pinch points and hazardous moving parts.

Please be sure that those who operate BBI equipment receive proper training. *Never conduct maintenance or repairs unless the equipment is fully disabled with the power source turned off. Never stand inside the unit while in operation or moving. Since we design our spreaders to project materials in patterns ranging from 30 to 90 feet, depending on the specific equipment, standing too close to equipment can result in injury. Please use extreme caution when operating all farm equipment.*

Thank you for choosing BBI spreading equipment. You will be glad you did.



Richard B. Hagler

President

“Driving Value”

DELIVERY INSPECTION - CUSTOMER COPY

Liberty Pull-Type

WARRANTY REGISTRATION & DEALER INSPECTION FORM

To have a fully-executed warranty, the dealer must fill this form out at time of delivery. There is no warranty without a fully-executed warranty registration and dealer inspection form.

Model & Serial Number: _____

DEALER EQUIPMENT AND SAFETY INSPECTION REPORT

- Equipment is properly assembled
- Equipment configured as ordered
- Equipment is functional and operates properly
- All guards are in place
- All warning signs and safety signs are in place
- Modifications to equipment (write details below)

Comments / equipment modifications: _____

Signature of Set-Up Person

Dealer Name

Date



CUSTOMER'S WARRANTY REGISTRATION - CUSTOMER COPY

Liberty Pull-Type

Dealer name: _____	Customer name: _____
Address: _____	Address: _____
_____	_____
City, State, Zip: _____	City, State, Zip: _____
_____	_____
Date of Delivery: _____	Phone #: _____
Model & Serial Number: _____	Email Address: _____
_____	_____

CUSTOMER'S WARRANTY REGISTRATION

Customer's warranty protection on this equipment is only valid when this certification form is completed and signed by both the customer and dealer at the time of delivery of the equipment and registered with the manufacturer.

DEALER'S SIGNATURE INDICATES:

<input type="checkbox"/> Equipment operates properly and customer was instructed in safe and proper operation
<input type="checkbox"/> Customer received a copy of the operator's manual
<input type="checkbox"/> Warranty was explained to the customer
<input type="checkbox"/> Electronic Rate control programmed and operates correctly

Signature of Dealer

Dealer Name

Date

CUSTOMER'S SIGNATURE INDICATES:

<input type="checkbox"/> Acceptance of equipment
<input type="checkbox"/> Receipt of owners manual and clear understanding of warranty
<input type="checkbox"/> All systems were explained and understood
<input type="checkbox"/> Receipt of instructions on safe and proper use
<input type="checkbox"/> If equipped with Electronic Rate control, this system was explained and owners manual was received
<input type="checkbox"/> A dealer parts/service representative contact has been provided (see page 28)

Signature of Customer

Customer Name

Date



TRACTOR-SUPPLIED HYDRAULICS - CUSTOMER COPY

Liberty Pull-Type

IMPORTANT TRACTOR-SUPPLIED HYDRAULIC SYSTEMS INFORMATION

IMPORTANT!



On units equipped with tractor-supplied hydraulics the return must be connected to a 0 (zero) pressure return. Gear motor systems require no pressure return.

DO NOT connect the system unless 0 (zero) pressure can be verified on return or damage to the motors will result! Connecting to a pressurized return will VOID THE WARRANTY.

Various tractor manufacturers use different language for their brand to identify a 0 (zero) pressure return. Please consult your manufacturer to insure the proper 0 (zero) pressure return is identified.

To maintain maximum operational efficiency, your tractor needs to have 21 GPM (Gallons Per Minute) overall and 2,000 PSI (Pounds per Square Inch) in order to operate the hydraulic spinner system. Lesser flow and pressure will deteriorate maximum performance.

Signature of Dealer

Dealer Name

Date

Signature of Customer

Customer Name

Date

WARRANTY

Liberty Pull-Type

WARRANTY

BBI warrants, to the original user, that each product of its manufacture is free from defects in material and workmanship if serviced and operated under normal conditions for 180 days from the date of the customer's bill of sale.

BBI's obligation under this warranty is limited to the correcting of the defect(s) without charge at its factory or one of its authorized dealers. Transportation charges will be pre-paid. BBI requires the opportunity to examine all parts in question in order to determine the original cause of defect. Correction of such defects by repair to or supplying of replacements for defective parts shall constitute fulfillment of all obligations to the original user.

This warranty shall not apply to any BBI product which must be replaced because of normal wear, misuse, negligence or accident.

This warranty shall not apply to products which have been repaired or altered outside of the BBI factory without written factory authorization.

BBI shall not under any circumstances be liable for any incidental or consequential damages arising from the loss of property or other damages or loses owing to the failure or use of BBI products beyond the cost of repair or replacement of any defective product. The repair or replacement of defective product shall be the sole and only obligation of BBI.

EXCEPT AS SPECIFICALLY SET FORTH HEREIN, BBI MAKES NO WARRANTY ON ITS PRODUCTS (EXPRESSED, IMPLIED OR STATUTORY) INCLUDING, WITHOUT LIMITATION, NO WARRANTY OF FITNESS FOR A PARTICULAR PURPOSE OR MERCHANTABILITY.

No person, agent or dealer is authorized to give any warranties or make representations on behalf of BBI or assume for BBI any other liability in connection with any of its products unless made in writing by an officer of BBI.

Any warranty provision outside of these bounds needs to be negotiated before service commences. The warranty does not include transportation. Warranty service is provided by the dealer. It is the customer's responsibility to seek warranty from your dealer.

DEALER'S WARRANTY SERVICE CONTACT INFORMATION:

Dealer Service Representative:	_____
Phone number:	_____
Email:	_____



SAFETY INSTRUCTIONS

Liberty Pull-Type

SAFETY WARNINGS

Please read and understand the safety warnings contained in this manual before operation.



TAKE NOTE: THIS SAFETY ALERT SYMBOL, FOUND THROUGHOUT THIS MANUAL, IS USED TO CALL YOUR ATTENTION TO INSTRUCTIONS INVOLVING YOUR PERSONAL SAFETY AND THAT OF OTHERS; FAILURE TO FOLLOW THESE INSTRUCTIONS MAY RESULT IN INJURY OR DEATH.

In this manual and on safety signs placed on your spreader, the words “DANGER”, “WARNING,” “CAUTION,” and “IMPORTANT” are used to indicate the following:

DANGER!



Indicates an imminently hazardous situation that, if not avoided, WILL result in death or serious injury. This signal word is to be limited to the most extreme situations and typically for machine components that, for functional purposes, cannot be guarded.

WARNING!



Indicates a potentially hazardous situation that, if not avoided, COULD result in death or serious injury. This includes hazards that are exposed when guards are removed. It may also be used to alert against unsafe practices.

CAUTION!



Indicates a potentially hazardous situation that, if not avoided, MAY result in moderate or minor injury. It may also be used to alert against unsafe practices.

IMPORTANT!



Indicates critical information regarding potential damage or deterioration of equipment if not heeded. Generally would not involve personal injury.

We cannot stress enough the need for personal safety. BBI strongly urges you to make safety your top priority when operating any equipment. We firmly advise that anyone allowed to operate our equipment must be thoroughly trained and tested to prove that they understand the fundamentals for safe operation.

Our intention is that the following guidelines cover general usage of BBI equipment and assist you in avoiding accidents. There will be times when you will run into situations that are not covered in this section. At those times, the best standard to use is caution guided by your own common sense. If, at any time, you have a question concerning these guidelines, please call your authorized BBI dealer or the BBI factory at (800) 282-3570.

SAFETY INSTRUCTIONS

Liberty Pull-Type

AVOID ACCIDENTS

Most accidents, whether they occur in industry, on the farm, at home, or on the highway, have causes stemming from the failure of individuals to follow simple and fundamental safety rules and precautions. For this reason, people can prevent most accidents by recognizing their real, potential causes and rectifying these causes before they ever allow accidents to occur.

Regardless of the care used in the design and construction of any type of equipment, there are many conditions that we cannot completely safeguard against without interfering with reasonable accessibility and efficient operation.

A CAREFUL OPERATOR IS THE BEST INSURANCE AGAINST AN ACCIDENT. THE COMPLETE OBSERVANCE OF ONE SIMPLE RULE WOULD PREVENT THOUSANDS OF SERIOUS INJURIES EACH YEAR.

THAT RULE IS:

NEVER CLEAN, OIL, OR ADJUST A MACHINE WHILE IT IS UNDER POWER.

- National Safety Council

CAUTION!



If you use your spreader to transport chemicals, check with your chemical supplier regarding the applicable DOT (Department of Transportation) regulations.

SAFETY DECALS



DECAL MAINTENANCE INSTRUCTIONS

1. Keep safety decals and signs clean and legible at all times.
2. Replace safety decals and signs that are missing or have become illegible.
3. Replaced parts that displayed a safety sign should also display the current safety sign.
4. Safety Decals are available from your local BBI dealer's Parts Department or our factory at BBI.

SAFETY INSTRUCTIONS

Liberty Pull-Type

HAZARDS

1. Refrain from wearing loose fitting clothing on or around this piece of machinery. There are many places that loose clothing may become wrapped or pulled into devices.
2. Be aware of any moving parts on this machinery. Make sure that any person or persons on or around this piece of machinery are aware of the dangers as well. There are many places where injury may occur. Learn about your unit and the dangers of it. Always use caution in the operation of this piece of machinery.
3. Be sure that any individuals operating this equipment are trained and are aware of the dangers of this equipment.
4. Check for rocks, sticks, or anything of solid mass that may cause bodily harm to you or damage your unit.
5. Never attempt to work on or repair this piece of equipment while it is running. The P.T.O. and/or any other power source must be completely disengaged while working on this unit.
6. Those working around this unit should remain at least 100 feet from it while it is in operation. The fans are able to propel objects at a high speed up to this distance.
7. Use extreme caution while operating the driven portion of this unit. Its size may limit your field of vision.
8. Be aware of the dangers of hydraulic systems. Hydraulic fluid is under very high pressure, and may cause serious injury if it hits the facial area, especially the eyes.
9. Shut down the entire system before checking hydraulic fluid level or adding fluid to the system.



TRACTOR PREPARATION AND HOOK-UP

Liberty Pull-Type

PRIOR TO START-UP

Look over the entire unit, checking that all guards and fasteners are in place and fasteners are properly tightened, including lug nuts.

IMPORTANT!



NOTE: Do not load spreader with material until after completing initial start-up steps.

TRACTOR PREPARATION AND HOOK-UP

1. Adjust tractor hitch and drawbar as close to horizontal as you can. Adjust drawbar so hitch pin hole is directly below center line of PTO shaft. Make sure drawbar is in a stationary position.
2. Back tractor to spreader and connect with a minimum 3/4" diameter hitch pin. Secure with a locking or cotter pin.

WARNING!



Pressurized hydraulic fluid can penetrate body tissue and result in death, serious infection, or other injuries. Fluid injected under skin must be IMMEDIATELY removed by a surgeon familiar with this type of injury. Make sure connections are tight and hoses and fittings are not damaged before applying system pressure. Leaks can be invisible. Keep away from suspected leaks. Relieve pressure before searching for leaks or performing any system maintenance.

IMPORTANT!



Ensure that you always keep your hose ends clean using a cloth. Never use a dirty coupling. If it does drop in the dirt, clean it up before you apply or damage to your tractor can occur.

3. Attach the safety chains.
4. Raise jack stand.
5. Either connect hydraulic hoses (as discussed in the Tractor-supplied Hydraulic Section), or connect PTO shaft to tractor PTO in the case of PTO Driven Spinners. Be cautious of pinch points.
6. Check to be sure that no loose parts or other material are in the hopper, on the conveyor or on the spinners. Be sure to remove any loose pieces and ensure all guards are in place.

HYDRAULIC CONFIGURATION

Liberty Pull-Type

1. TRACTOR-SUPPLIED - HYDRAULIC SPINNERS

For Liberty spreaders with spinners powered by the tractor's hydraulic system, you will need to connect two sets of remotes one set for the hydraulic cylinder and one for the spinners. Make sure that you match and properly connect the pressure and return hoses with each set of remote ports. *Mismatched hoses or return hoses that are not properly connected may cause damage to hydraulic components on the spreader.*

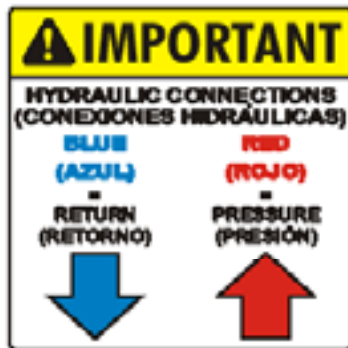
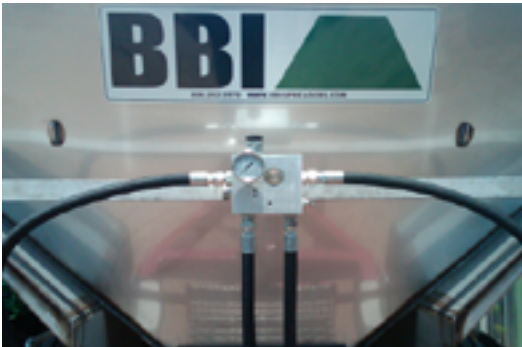

All Tractor-Supplied Hydraulic Systems include the Hydraulic Connections label. This indicates that the blue hose is for Return and the red hose is for Pressure.

IMPORTANT!



On units equipped with tractor-supplied hydraulics the return must be connected to a 0 (zero) pressure return. Gear motor systems require no pressure return.

DO NOT connect the system unless 0 (zero) pressure can be verified on return or damage to the motors will result! Connecting to a pressurized return will **VOID THE WARRANTY**.

Various tractor manufacturers use different language for their brand to identify a 0 (zero) pressure return. Please consult your manufacturer to insure the proper 0 (zero) pressure return is identified.

To maintain maximum operational efficiency, your tractor needs to have 21 GPM (Gallons Per Minute) overall and 2,000 PSI (Pounds per Square Inch) in order to operate the hydraulic spinner system. Lesser flow and pressure will deteriorate maximum performance.

SPINNER SPEED ADJUSTMENT: HYDRAULIC SPINNERS

ELIMINATOR MANIFOLD

The Eliminator Manifold is designed to protect your hydraulic spreader components from harm. It alleviates deadhead, cross hook-up, and over-pressure situations. The hoses can be hooked up backwards, or the return not plugged in, and the Eliminator should protect the motor from harm. It contains flow control, pressure relief, and a spinner system pressure gauge. This gauge monitors working pressure. Working pressure is the pressure required to do the work and provides no indication of available pressure.

SPINNER SPEED - MANUAL FLOW CONTROL

Spinner speed is adjusted manually by adjusting the flow control valve located on the top of the Eliminator manifold. When desired speed is achieved, use the locking nut to lock valve in place.

Spinner speed can also be adjusted with your Tractor's Hydraulic System

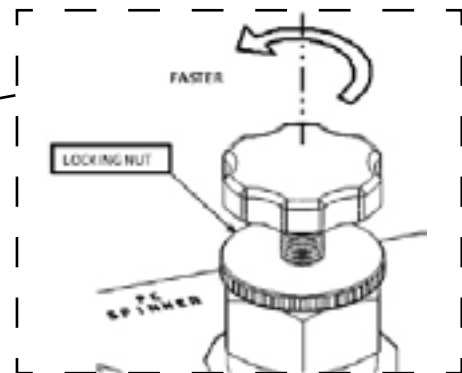
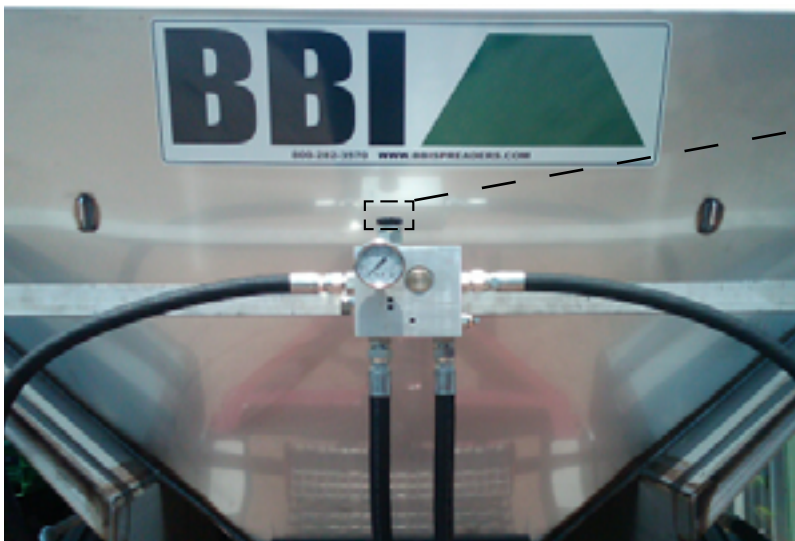

2: PTO DRIVEN - MECHANICAL SPINNERS

PTO driven spinners are controlled by PTO input speed. BBI PTO driven Spinners are designed to run at 540 or 1000 RPM tractor PTO speeds respectively. The best operation can be found by turning the spinners at the proper speed.

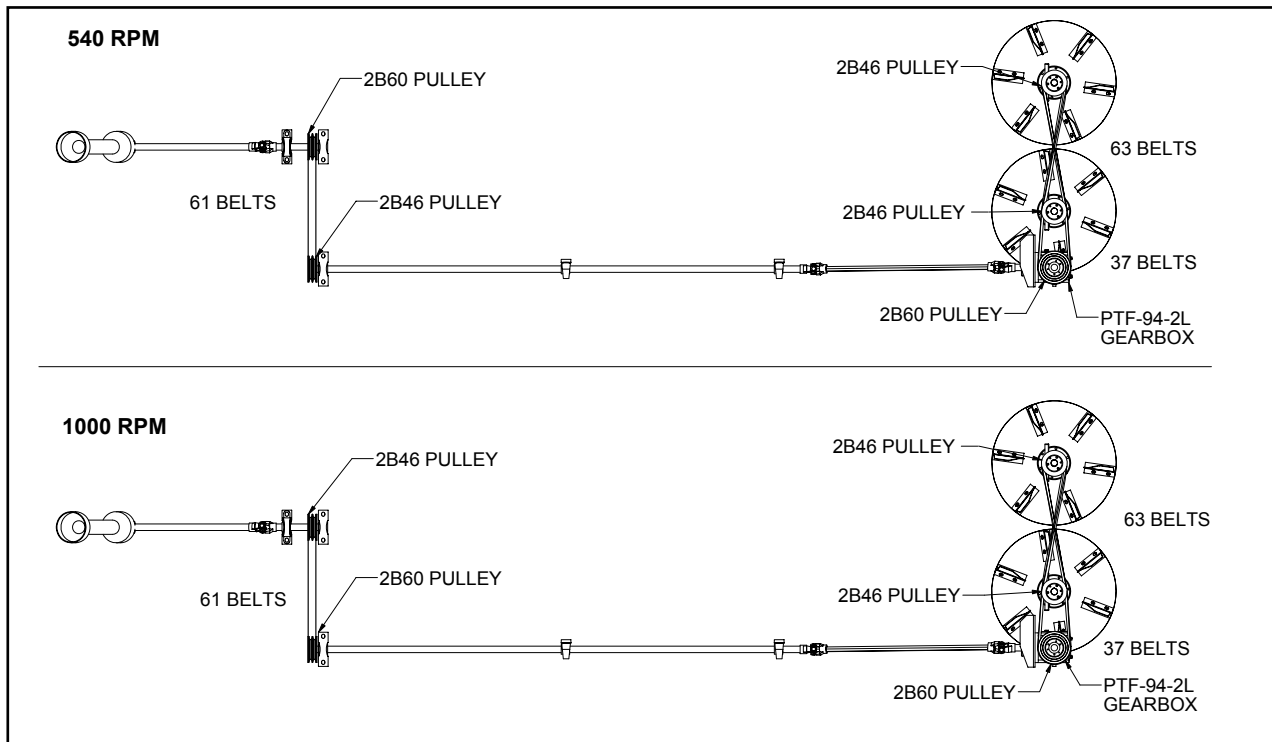

INITIAL STARTUP

Liberty Pull-Type

SETTING THE DUAL SPEED PRESS WHEEL

1. Make sure all moving parts are disengaged.
2. Loosen Idler sprocket.
3. Set the Jump chain to the desired sprocket ratio.

STANDARD RATES: 11 tooth cog -to- 60 tooth cog is normally used for
FERTILIZER

HIGH RATE: 26 tooth cog -to- 45 tooth cog is normally used for
LIME

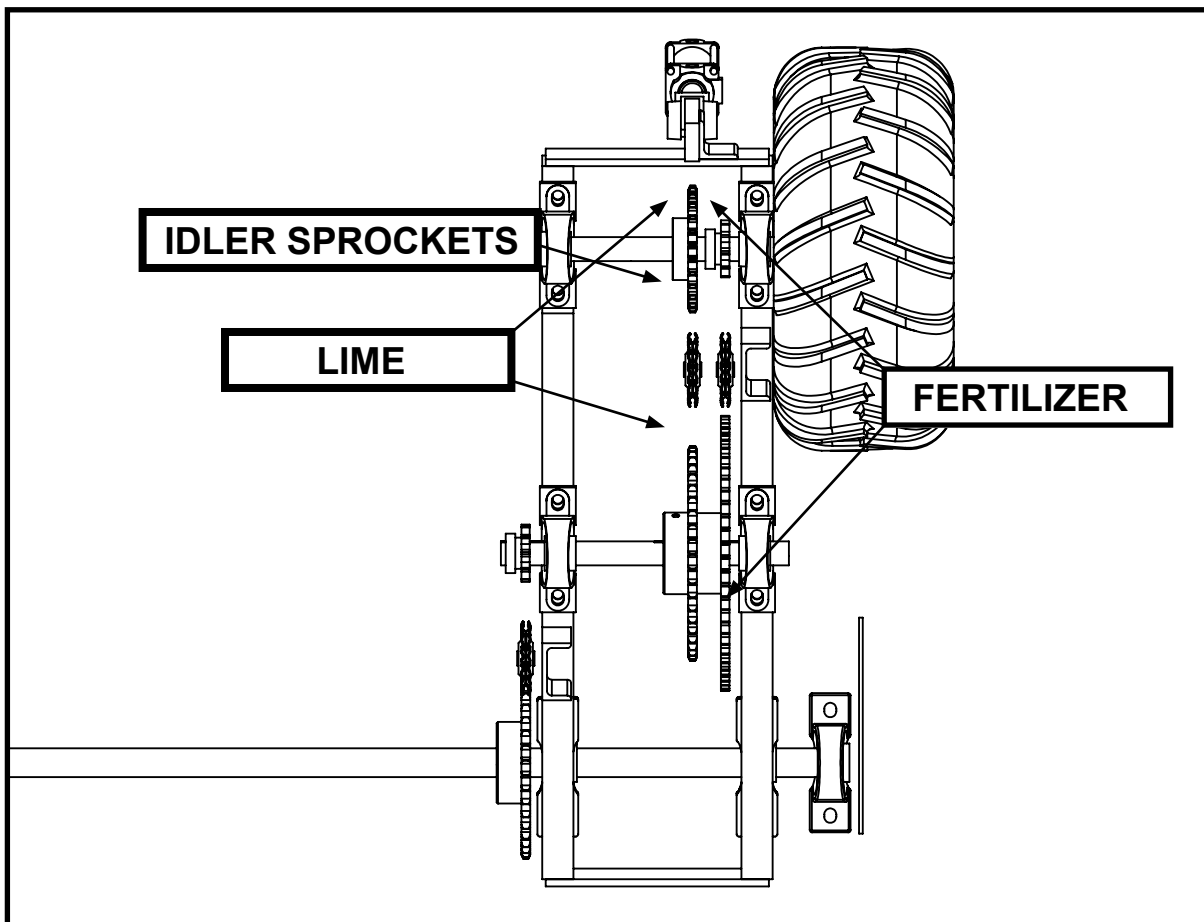
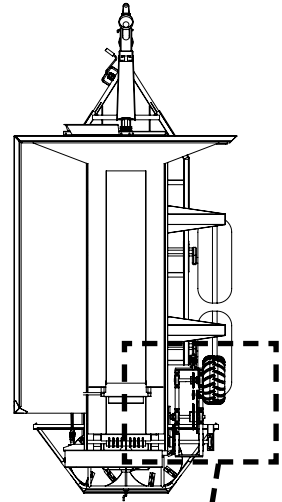

GENERAL OPERATING PROCEDURES

Liberty Pull-Type

GENERAL OPERATING PROCEDURES

Check over entire unit to be sure all guards and fasteners are in place and fasteners are properly tightened.

NOTE: Stand clear of moving machinery.

To operate the spreader, the following sequence should be observed:

1. Securely attach spreader to towing unit. ATTACH SAFETY CHAINS.
2. Adjust dual speed press wheel to appropriate setting.
3. Connect PTO shaft to tractor PTO if using PTO Spinners.
4. Attach Press wheel cylinder hoses to tractor remote ports. Be sure hose fittings are free of dirt or other material that may contaminate the hydraulic system.
5. Ensure that PTO is disengaged.
6. Drive to the location where spreading is to be done.
7. Fill the body with material to be spread.
8. Set the feed gate opening to obtain the desired yield.
9. Adjust the material flow divider to give the desired spread pattern.
10. If your unit has hydraulic spinners, adjust the tractor's hydraulic control valve to the setting required for the material used, based on the desired spread pattern.
11. Check to be sure that no loose parts or other material are in body, on conveyor or on spinner. Remove any loose pieces and ensure all guards are in place.
12. Check to make certain that no one is within 50 feet of the spinners. Engage PTO, which in turn engages the spinners in standard configuration.
13. Engage the PTO.
14. Engage the hydraulic press wheel cylinder.
15. Begin Field Testing spreader.

CAUTION!



DO NOT check leaks with hands while system is operating, as high-pressure oil leaks can be dangerous! DO NOT check for leaks adjacent to moving parts while system is operating, as there may be danger of entanglement.

IMPORTANT!



Before spreading material, spread pattern tests must be conducted to properly adjust the spreader. THE MANUFACTURER OF THIS SPREADER WILL NOT BE LIABLE FOR MISAPPLIED MATERIAL DUE TO AN IMPROPERLY ADJUSTED SPREADER.

FIELD TESTING

Liberty Pull-Type

FIELD TEST

Prior to first use of the machine for each spreading season, as well as following any major repair or overhaul, you should field test your machine to verify that all systems and components are functioning properly. You should execute field testing on any suitable course that will allow the spreader to be driven at similar speeds used during spreading.

CAUTION!



To observe conveyor and spinners while the vehicle is in motion, you must take proper safety precautions. These safety precautions may include use of mirrors clamped to permit safe observation, following the spreader in another vehicle at a safe distance, or other suitable means. *DO NOT stand in the hopper or on any part of the spreader, as there is danger of falling off the vehicle or into moving machinery. Use great care while performing this test.*

SPREAD PATTERN

Liberty spreaders are capable of accurately broadcasting a consistent, flat pattern of material up to 80 feet wide. *The equipment may throw material at much greater distances, but the most effective patterns are most likely at distances up to 80 feet wide. The driving interval should equal the swath.*

FACTORS AFFECTING THE SPREAD PATTERN

Many of the following conditions may affect your equipment's spread pattern performance:

1. Flow divider position
2. Spinner blade position
3. Spinner speed
4. The condition of the spinner blades on the spinner discs
5. Physical properties of material
 - a. Density
 - b. Size
6. Rate of delivery of material
7. Balance between deliveries to both spinners
8. Wind

Because most of these characteristics will change with each material spread, a certain amount of your own experience with both equipment and material, along with some testing on your part, will determine the adjustments needed to obtain the desired swath width and spread rate.

MATERIAL SIZE AND DENSITY

The particle size is one aspect that determines the maximum spread pattern width. The spread pattern can vary anywhere from 25 feet for powder-type materials, such as lime, or up to 80 feet for granular fertilizer.

The density of the material also affects the pattern. The spreader will throw large, dense particles farther than finer materials with lower density.

Size is more important than density in determining the distance a particle is thrown.

FIELD TESTING

Liberty Pull-Type

SPREAD PATTERN TESTING

TEST KIT

Not included; available for purchase separately from BBI.

A spread pattern test kit should contain the following items:

- Plastic pans - consistent size and shape
- Test tube or vessel - one for each pan - test tube rack will help
- Funnel
- Tape measure
- Density Scale
- Marking flags or paint

SET UP

The test area should be at least 250 feet in length and as wide as necessary, depending on the swath width of the material to be checked.

Lay out test pans on a level area so the spreader can be driven into or with the wind. If the wind is greater than ten miles per hour, you should not attempt a spread pattern check.

Position the pans so the spreader can be running at least 100 feet before it reaches them and can continue spreading 150 feet beyond the pans. Place a marker at the beginning and end of the test area as guides for the operator.

Level the pans and place them at essentially the same height. Place a marker at the center of each pan so after the pans have been picked up they can be placed back in their original position without measuring.

Use the chart below to determine the interval that the pans should be placed. A swath width from 30 to 80 feet will be sufficient to check most spreaders.

SWATH WIDTH	NUMBER OF PANS NEEDED	INCHES BETWEEN EACH PAN (center to center)
30'	7	60"
40'	9	60"
50'	10	60"
60'	11	60"
70'	13	60"
80'	17	60"

SPREAD TEST

To get a true representation of the spread pattern, you'll need two passes across the pans. On the first pass, line up the spreader with one of the pans on the end. Start spreading material at least 100 feet before the pans and continue at least 150 feet beyond the pans. Repeat the process for the second pass on the opposite end of the line of pans.

Make sure to run both passes in the same direction so that you get a sample from both spinners.

Collect the material from each pan into corresponding test tubes to view the pattern. Depending on the pattern, adjustments to the spreader may be necessary.

FIELD TESTING

Liberty Pull-Type

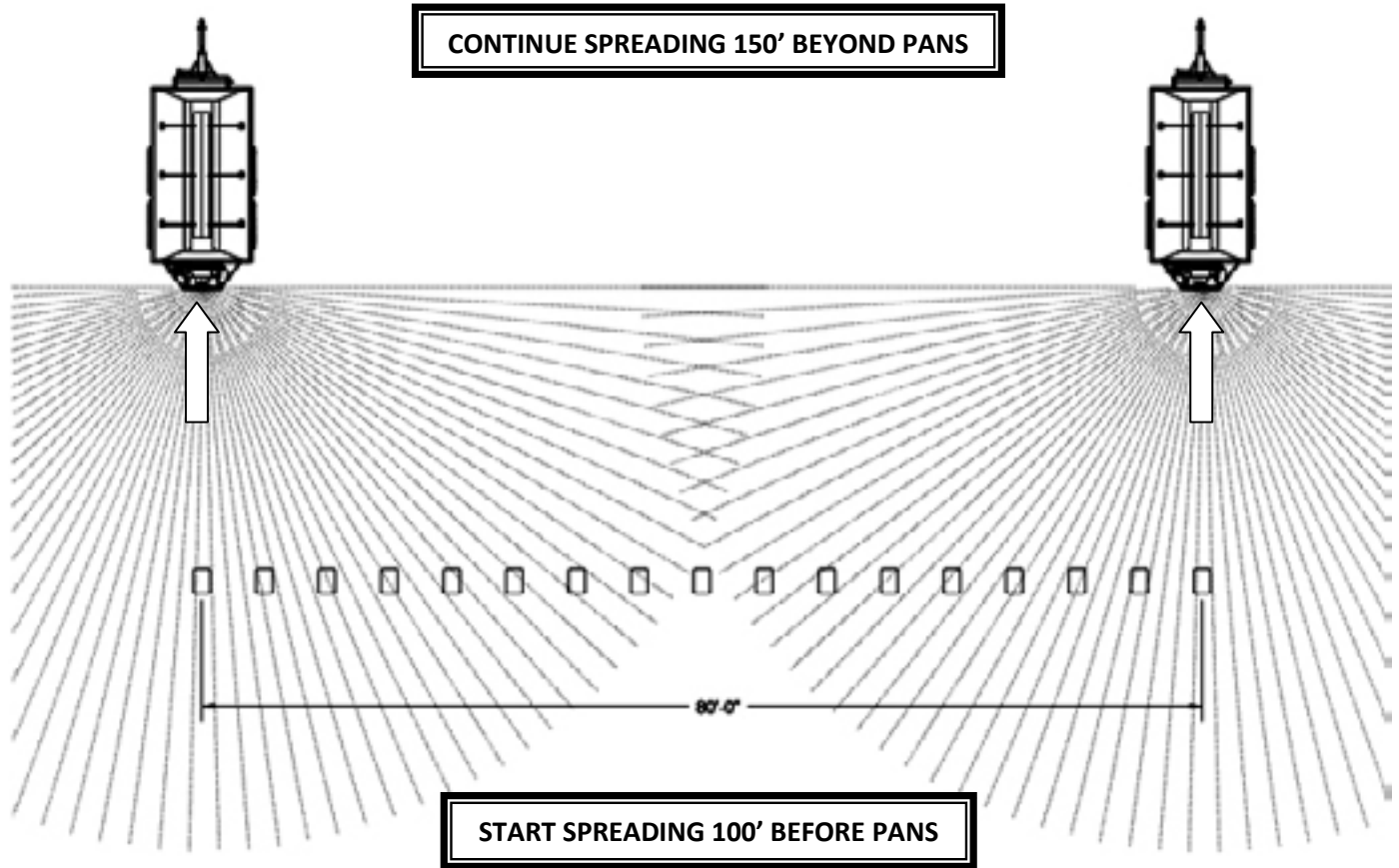

EVALUATION

By running in the same direction across both ends of the pans, you should be able to see an even distribution of material in the test tubes.

Liberty spreaders are capable of producing a flat pattern, but you may see slight variances in the pattern, due to the terrain used for testing, irregular materials, and/or other abnormalities.

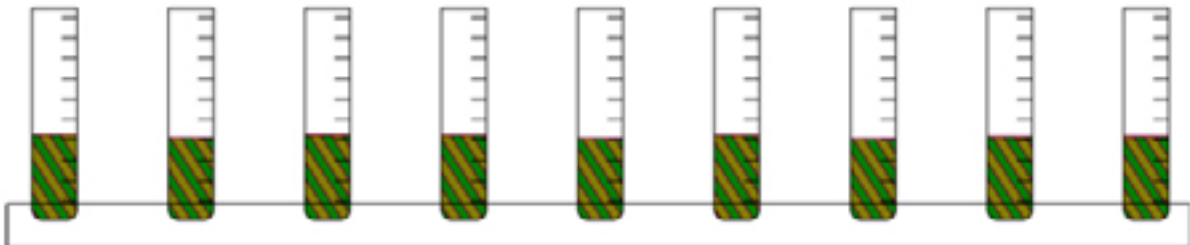

FIELD TESTING

Liberty Pull-Type

ADJUSTMENTS

You can change the spread pattern by adjusting the flow divider, spinner blades, and spinner speed. For initial calibration, adjust the flow divider and check the pattern. If the flow divider adjustments do not produce the desired spread pattern, then you may need to adjust the spinner speed or blades.

FLOW DIVIDER

Moving the flow divider will not make the spread pattern wider—it will only change the distribution of material within the pattern. Adjust the flow divider forward using the handle to increase the amount of material being applied directly behind the spreader. Adjust the flow divider toward the rear to throw more material to the sides of the spreader. There is a marked rule to locate on the left side of the flow divider.

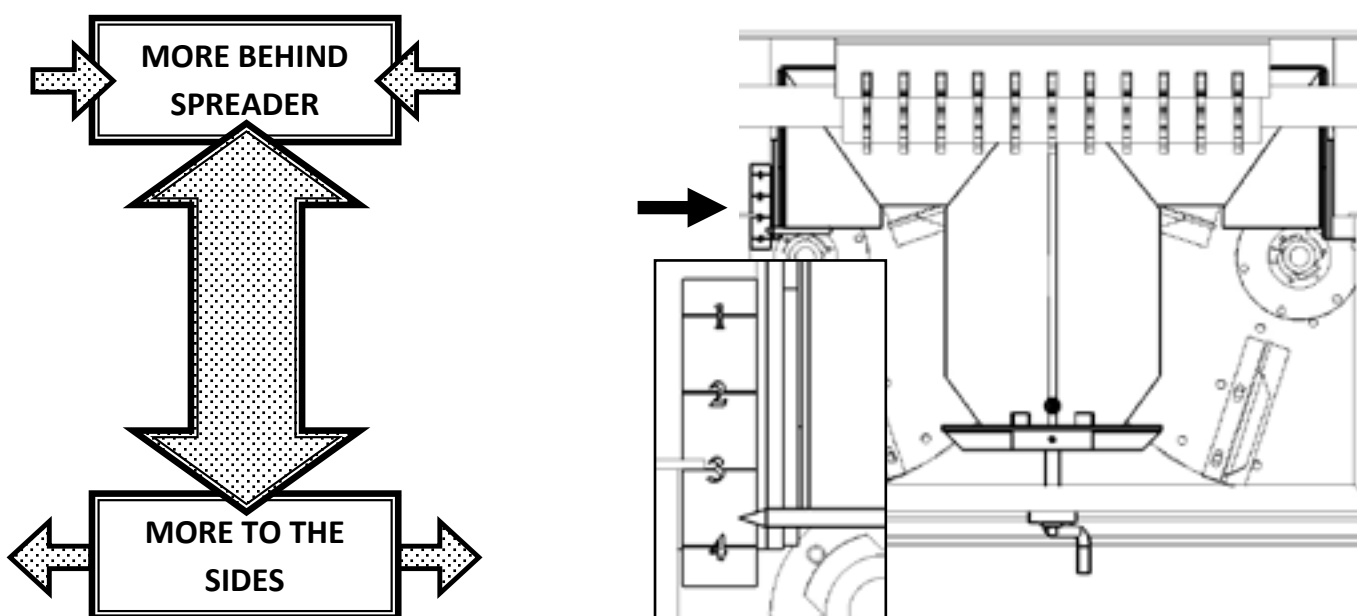

In the center of the flow divider, you'll see a removable insert. You'll use this insert for spreading fertilizer, and you'll remove it when spreading lime. As a starting point, set the flow divider on 3-1/2 when spreading fertilizer, and set it on 1 when spreading lime. **ALWAYS TEST AND CALIBRATE THE SPREADER PROPERLY PRIOR TO OPERATING IN THE FIELD**

FLOW DIVIDER SETTINGS		
As a starting point, set the flow divider on the following:		
Fertilizer	=	3-1/2 (USE INSERT)
Lime	=	1 (REMOVE INSERT)

REMOVE INSERT FOR SPREADING LIME

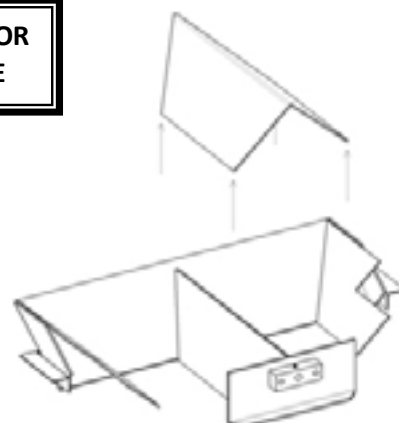

Materials need customer-specific adaptation to suit regional variations. Please be sure to adjust your flow divider when changing materials to optimize the spread pattern.

MACHINE OPERATION

Liberty Pull-Type

SPINNER FINS

You can adjust the spinner fins to three different positions: straight, forward, and backward. Moving the fins **FORWARD** causes more material to be thrown to the sides of the spreader. Placing the fins in the **BACK** position causes more material to be thrown directly behind the spreader. Standard factory installation for the fins is in the straight position. Use only genuine BBI parts. Spinner fins are designed to be replaced periodically.

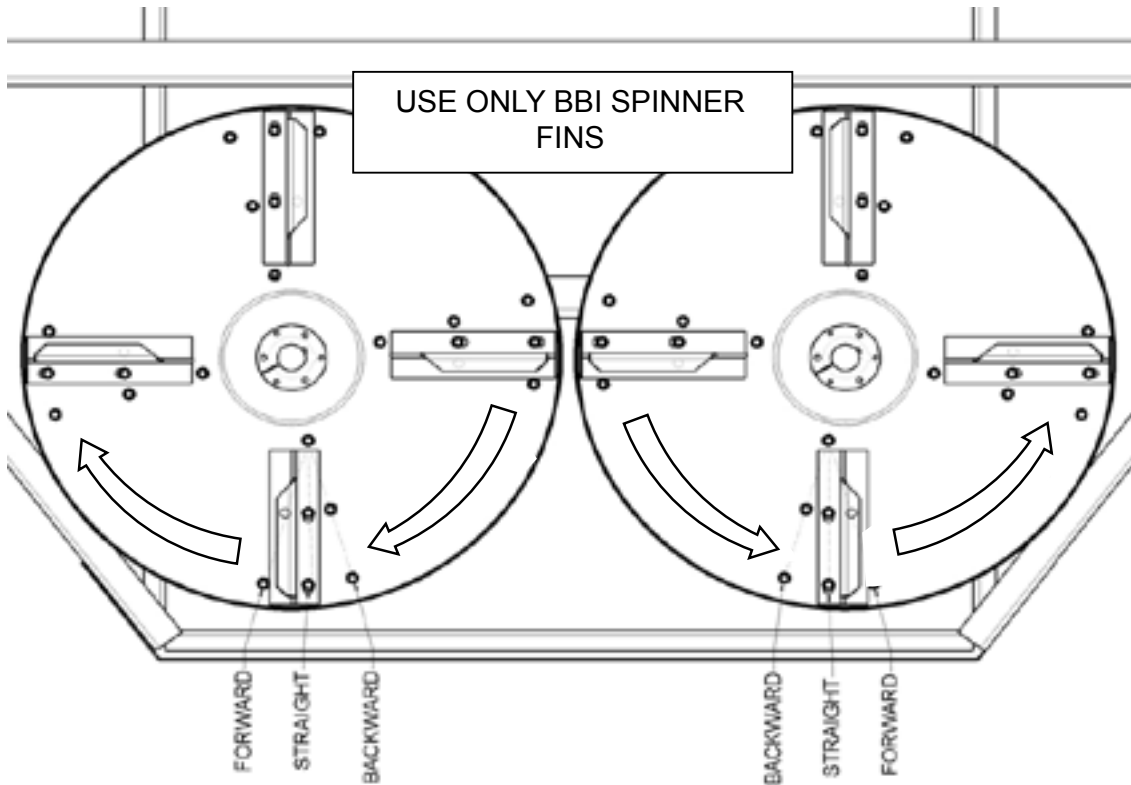

Spinner fins will wear and disfigure from the abrasiveness of the materials. Excessive wear can cause an uneven spread pattern. You should replace worn fins before they affect the spread pattern (fins are available for purchase from your nearest BBI dealer or through the parts department at BBI)

SPINNER SPEED

Predicting how an increase or decrease in spinner speed will affect the spread pattern is difficult. You should make this particular adjustment only after other methods of adjustment fail to give a satisfactory pattern. Increasing spinner speed may increase or decrease the material directly behind the spreader, depending on the material being spread, the original spinner RPM, and type of blade setting. *You will have to use trial and error to make adjustments with spinner speed, due to the lack of predictability with this type of adjustment.*

SPINNER SPEED RECOMMENDATIONS

- *Fertilizer (80 ft Wide) = 850-900 RPM
- Fertilizer (60 ft Wide) = 650 RPM
- *Lime (60 ft Wide) = 600-650 RPM

* Must have tractor supplied hydraulic spinners and 21 GPM @2000 PSI.

APPLICATION RATE

Always TEST and CALIBRATE the spreader properly prior to operating in the field.

The speed of the conveyor and the height of the gate opening combine to determine the amount of material being applied at a given time (the application rate). Elements that also affect the application rate include the material density, swath width, and ground speed.

When adjusting application rates, keep these principles in mind:

- Bed chain increases = Rate increases
- Gate height increases = Rate increases
- Material density increases = Rate increases
- Swath width increases = Rate decreases

SET GATE USING GAUGE

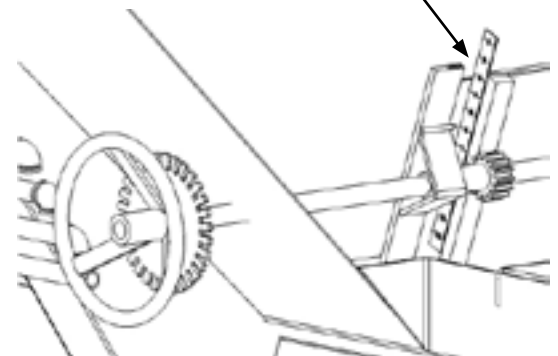

ACCURATE METERING OF FERTILIZER MATERIALS

Once an adequate spread pattern has been obtained, the spreader should be calibrated to deliver the desired rate per acre.

Tables for determining the gate setting can be found on the spreader decal on the side of the hopper or in the Appendix. Many application issues can be traced to incorrect product density. Density is very important to a proper application. The guesswork of estimating the weight per cubic foot of a blend can be eliminated with the use of a density scale.

If a density scale is not available, then use one of the following calculations to determine density:

**Weight of 5 gallons of material (LBS) X 1.5 = Weight per cubic foot (LBS)
or Weight of 1 Gallon x 7.5**

After the spreader has been successfully calibrated and tested, it is ready for use.

Remember to USE EXTREME CAUTION and FOLLOW ALL SAFETY INSTRUCTIONS while operating this machinery.

LUBRICATION AND MAINTENANCE

Liberty Pull-Type

MAINTENANCE

The chemical agents in commercial fertilizers are very corrosive. It is important that a comprehensive preventative maintenance program be established. The cleaning, lubrication, and maintenance practices that you follow will affect the life, service, and overall cost-of-use of the spreader.

LUBRICATION

Frequently lubricate all bearings and other grease points to extend the life of the components. When lubricating, it is important to also inspect the components to ensure satisfactory operation.

The required interval of lubricating will depend on the operating environment. Conditions such as dust, moisture, speed, and temperature will affect how often to lubricate. Refer to the chart below for a guideline.



LUBRICATION SCHEDULE	
ITEM	FREQUENCY
Input Shaft U-Joint	40 hours
Input Shaft Bearing	40 hours
Front Roller Bearings	120 hours
Rear Roller Bearings	40 hours
Spinner Bearings	40 hours
Spinner U-Joints	80 hours
Gate Rod	500 hours
Flow Divider Bushing	500 hours
Wheel Hubs	40 hours
Walking Beam Suspension	**

Walking Beam Suspensions have grease points in the bushings along the pivot pin. Due to the suspension's design, you do **not have to lubricate the bushings (BBI has included fittings on these bushings for additional lubrication).

On PTO Driven Spinner Models, BBI has filled the Spinner Drive Gearbox with **90-weight oil** at the factory. You should replace the factory oil after the first 50 hours of break-in time. Thereafter, you should drain and refill the oil after every season.

LUBRICATION AND MAINTENANCE

Liberty Pull-Type

REAR ROLLER BEARING PLATES

You'll find the UHMW Polyethylene plates located behind the rear roller bearings. With the addition of this plate, a cavity has been created that is filled with grease which will help purge any debris that might cause damage or corrosion. Grease these bearings every 40 hours of operation for protection.

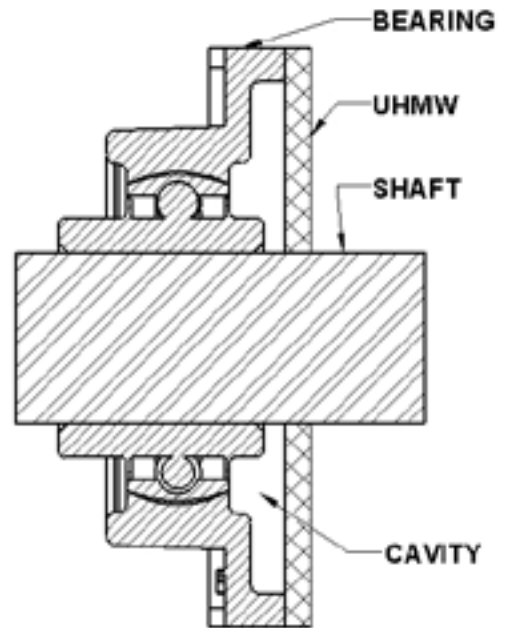
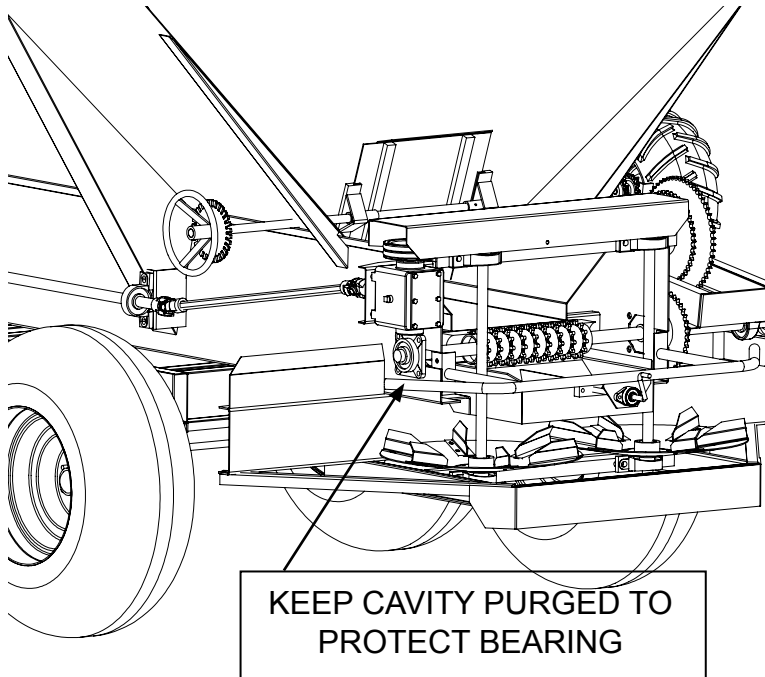

CHECK LUG NUTS DAILY

FASTENERS

Tighten all screw fasteners after the first week of operation and regularly thereafter. Replace any lost or damaged fasteners or other parts immediately upon finding such damage or loss.

LUG NUTS

Check lug nuts each time before using. Ensure lug nuts are tightened to the appropriate torque specification. For solid flat plate center wheels with 10-bolt hubs, tighten lug nuts to 250 ft/lbs. For 8-bolt hubs, tighten lug nuts to 120 ft/lbs. For 6-bolt hubs, tighten lug nuts to 120 ft/lbs.

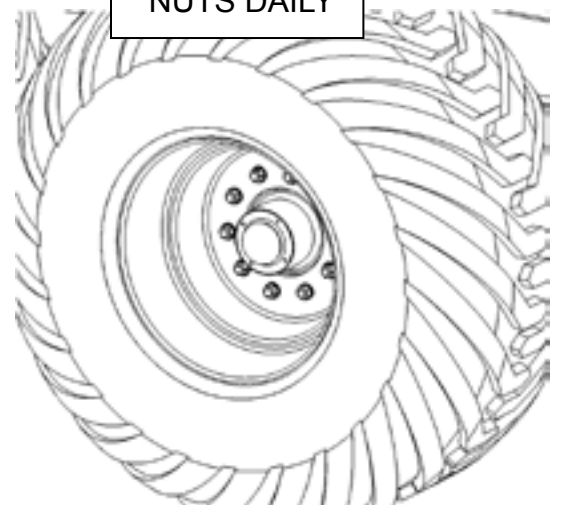

IMPORTANT!



Tightening lug nuts more than recommended can damage wheels.

CONVEYOR CHAIN ADJUSTMENT

Liberty Pull-Type

CHAIN TENSION

Conveyor chain tension is also a factor in conveyor and roller life. Note the proper chain tension illustrated below. Be sure the chain is tensioned equally on both sides. You can make adjustments on each side of the unit at the idler bearings located at the front of the unit.

A conveyor chain that is too tight will stretch more than normal and can also cause the roller shafts to break. If the chain is too loose then it can catch on the sub frame or get wrapped around the rear roller causing damage to the chain, roller, and hopper.

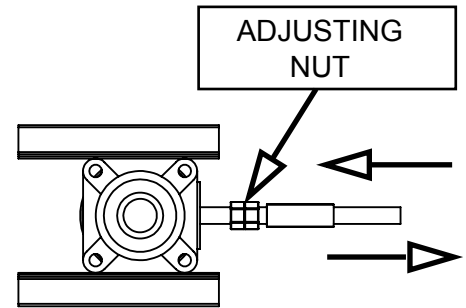

Front Roller Adjustment used to change chain tension.

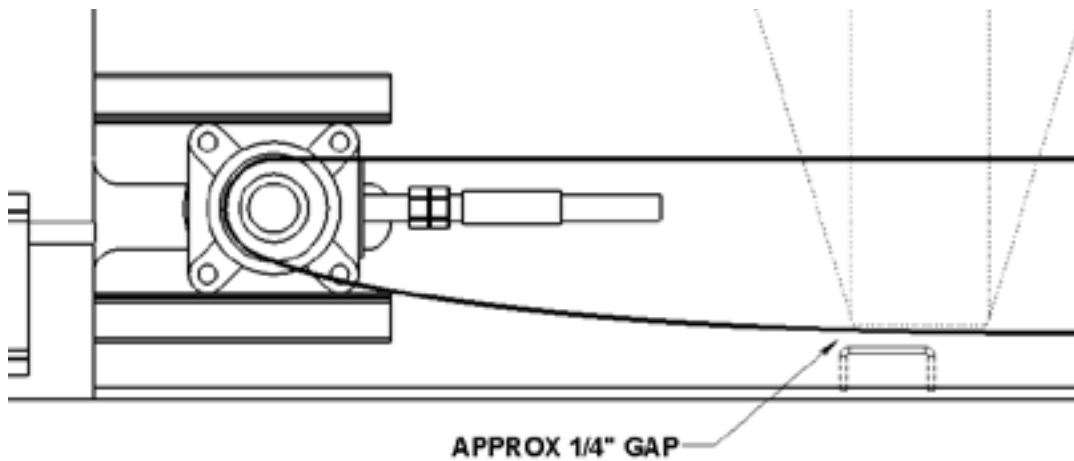

IMPORTANT!



Note: *Stainless steel mesh chain will stretch when first used. You must check the chain for appropriate tension and properly adjust it to avoid damaging unit. After initial break-in period, stretching should be minimal.*

CONVEYOR CHAIN ADJUSTMENT

Liberty Pull-Type

CONVEYOR TENSION ADJUSTMENT

When adjusting the conveyor chain, allow the bottom side of the conveyor to touch the cross members of the chassis inside the conveyor return tunnel.

NOTE: Conveyor Chain will stretch when first used. Chain must be checked for appropriate tension and properly adjusted to avoid damaging unit. After initial break in period stretching should be minimal.

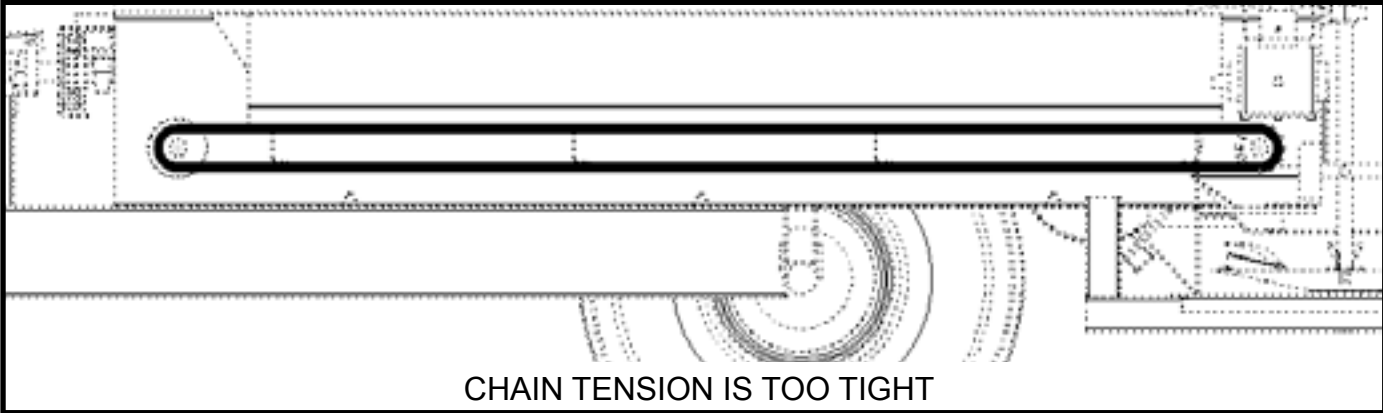
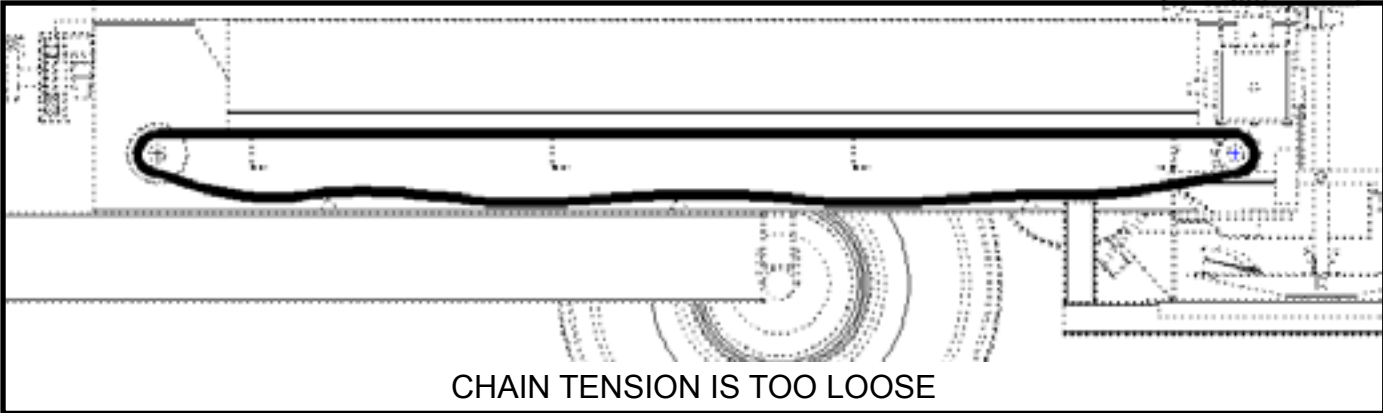
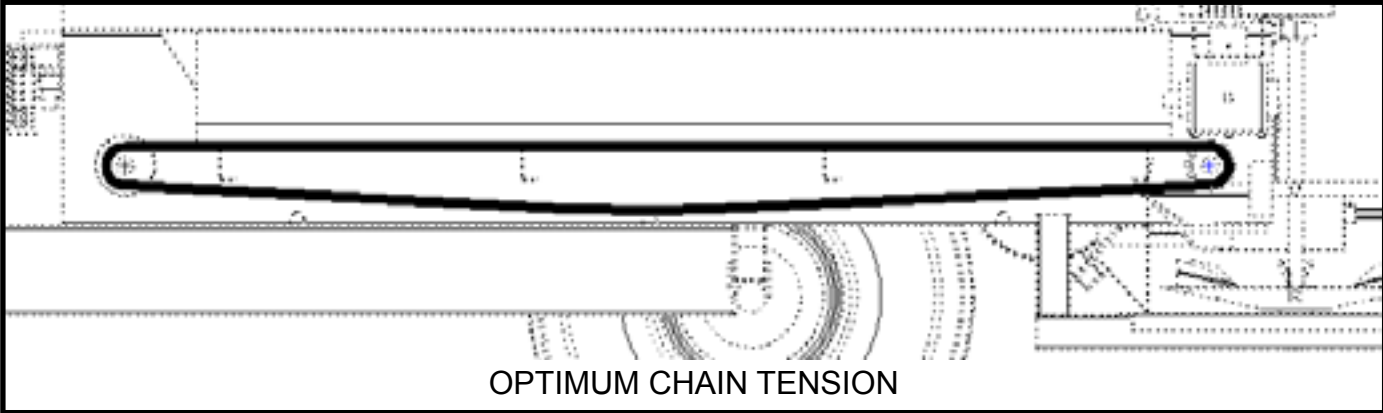

PTO DRIVEN SPINNER - BELT CONFIGURATION

Liberty Pull-Type

SPINNER GEAR CASE

Check the oil level in the gear case monthly. The oil in a new unit should be drained at the end of **first two weeks or 50 hours** and then thoroughly flushed with light oil. A good quality **90 weight oil** is used in BBI gearboxes. Refill the gear case with a recommended lubricant. After the initial change, the oil should be changed every 2,000 hrs. or annually, whichever is first. Notice the grease fitting for the top bearing. It needs grease twice per week during normal operations.

SPINNER BELT SETUP

When replacing worn spinner belts, it is important to install them correctly so that they do not wear out prematurely. Use the illustrations below for reference.

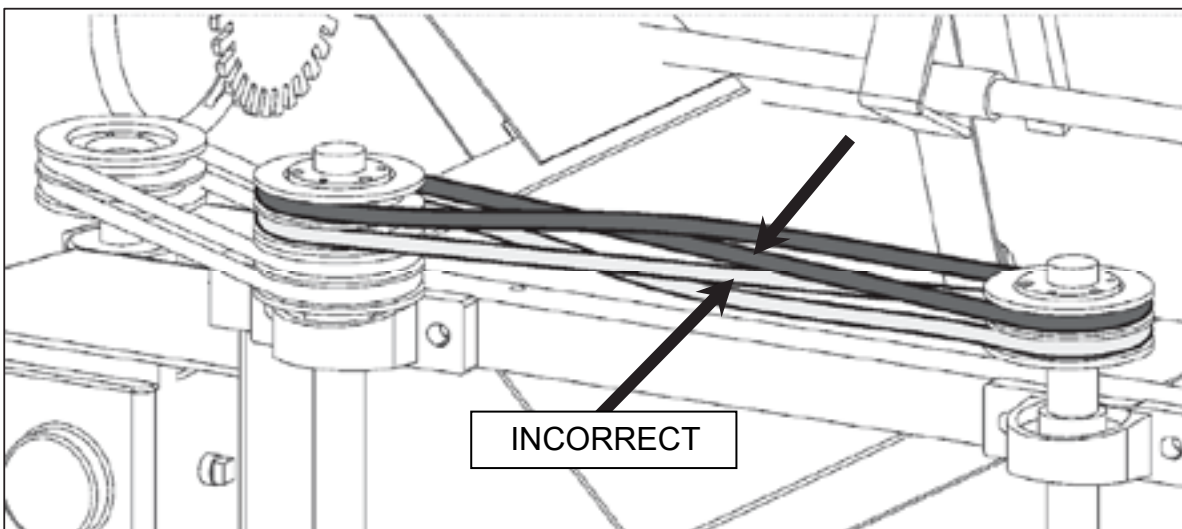
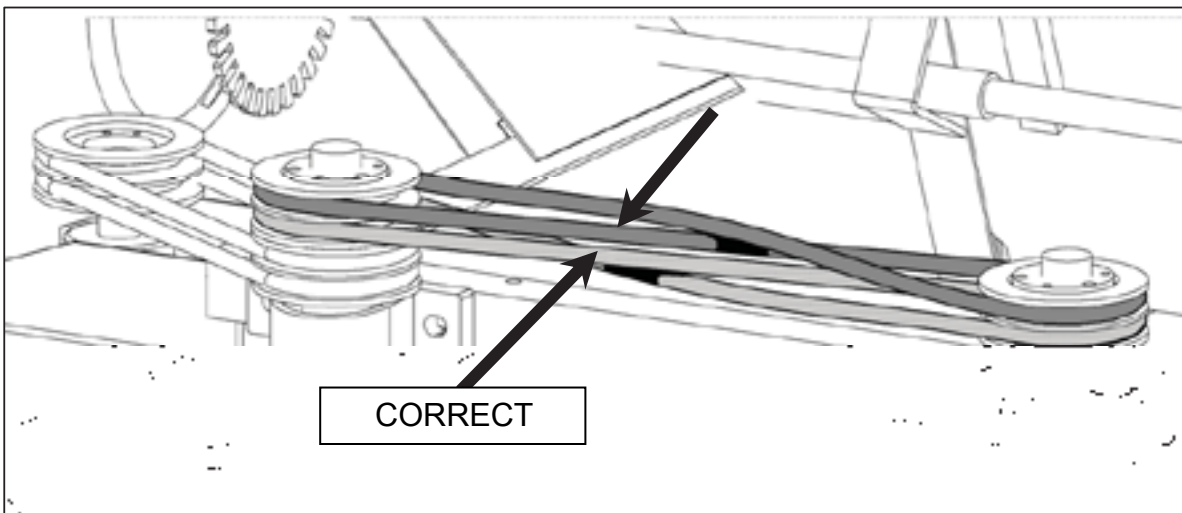

PARTS AND SHIPPING

Liberty Pull-Type

REPLACEMENT PARTS

Use only genuine BBI Parts.

Order parts from the authorized BBI dealer in your area.

When placing an order, please have available:

1. The model and serial number of the spreader.
2. The part name, part number, and the quantity required.
3. The correct street address for parts delivery, and your preferred carrier (if necessary)

DEALER'S PARTS DEPARTMENT INFORMATION:

Dealer Parts Representative:	_____
Phone number:	_____
Email:	_____

SHIPPING DAMAGE

You must make claims for shortages and/or errors immediately upon receipt of goods from BBI. When you receive broken or damaged goods, you must make a full description of the damage to the carrier agent on the freight bill. If insisted upon, you can always collect full damage from the transportation company. Please contact BBI as soon as possible after you have notified the carrier.

If the transportation company is not handling your claims to your full satisfaction, please contact BBI's Customer Service Department at 1-800-282-3570 for assistance.

Liberty Pull-Type

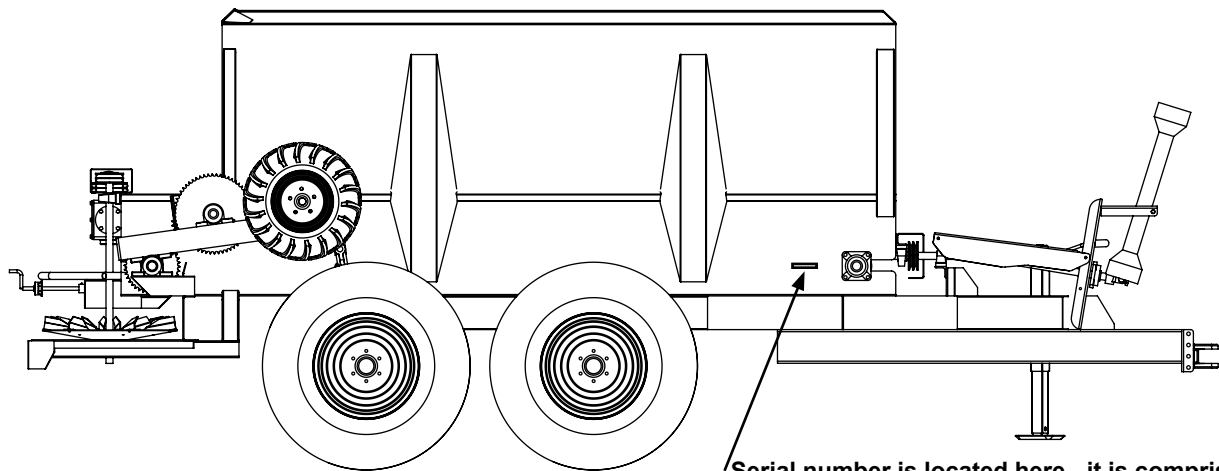

Serial number is located here - it is comprised of 4 digits. Please have this number available when ordering replacement parts.

PARTS INFORMATION

Information contained in this section is provided for identification and reference purposes when ordering replacement parts.

- 1). Identify the part or component that needs to be replaced.
- 2). Locate the appropriate section on the following pages where the part is located.
- 3). Reference the appropriate page to gather necessary part number and pertinent information.

REPLACEMENT PARTS ORDERING:

You have several options when ordering replacement parts:

- 1) Call your service dealer
- 2) Order through BBI's parts website: www.bbispreaders.com

ASSEMBLY IDENTIFICATION

Liberty Pull-Type

COMPONENT / ASSEMBLY IDENTIFICATION:

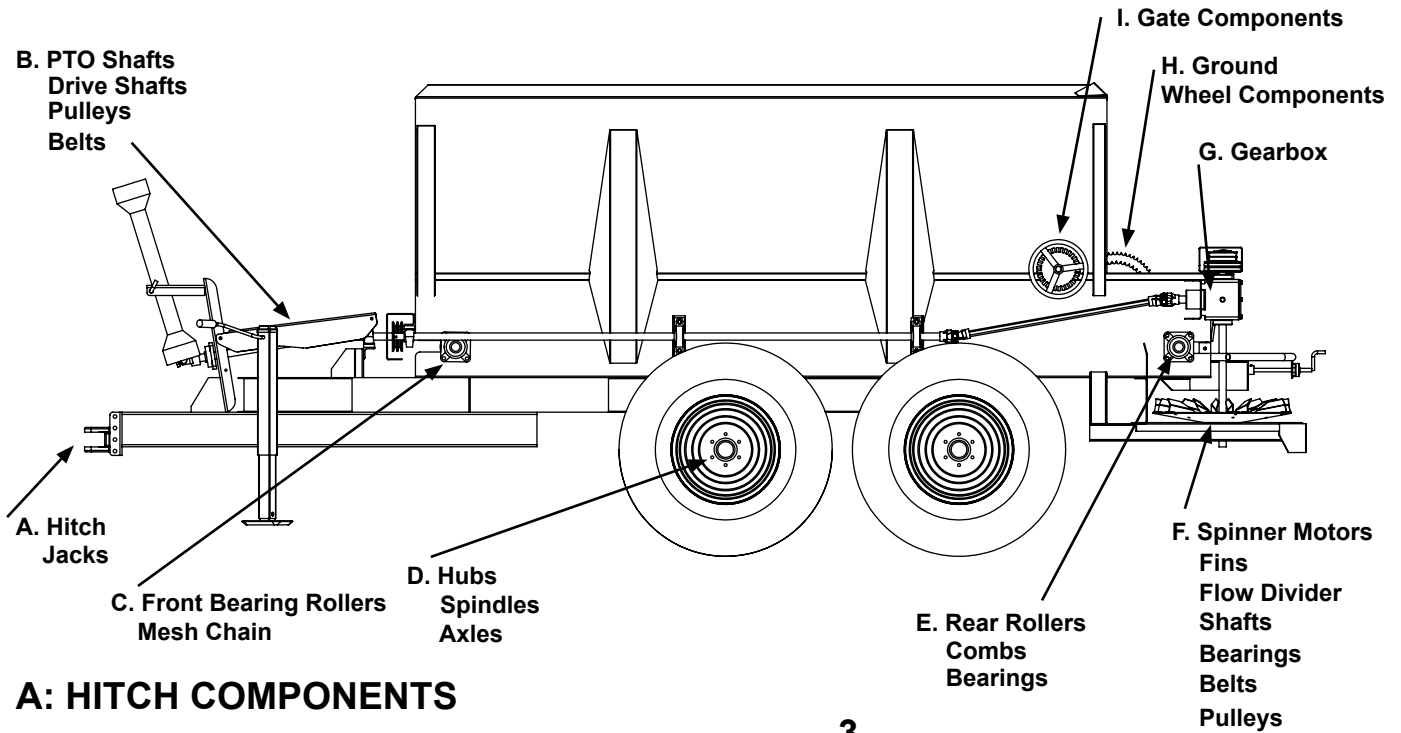

A: HITCH COMPONENTS

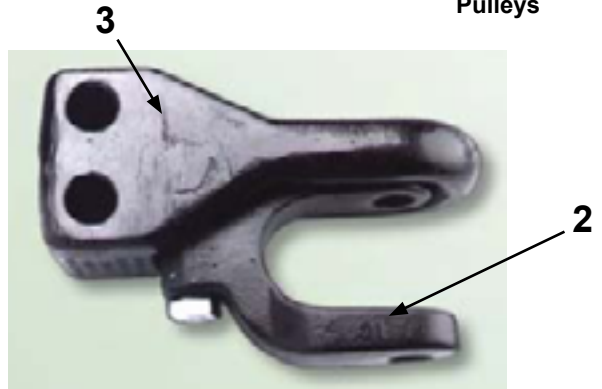

ITEM	PART NO.	DESCRIPTION	QTY
1.	24PPHB305	Hitch Bracket	1
2.	24PPI208VR	Perfect Hitch Clevis	1
3.	24PPI401V3	Perfect Hitch Pintle	1
4.	24PPI401V3A	Perfect Hitch Assembly	1
5.	24H20078	Heavy Duty Hitch	1

ITEM	PART NO.	DESCRIPTION	QTY
1.	24SWL190DL	7K Jack	1
2.	24182304	10K Jack	1

ASSEMBLY IDENTIFICATION

Liberty Pull-Type

B: PTO SHAFTS, DRIVE SHAFTS, PULLEYS, BELTS

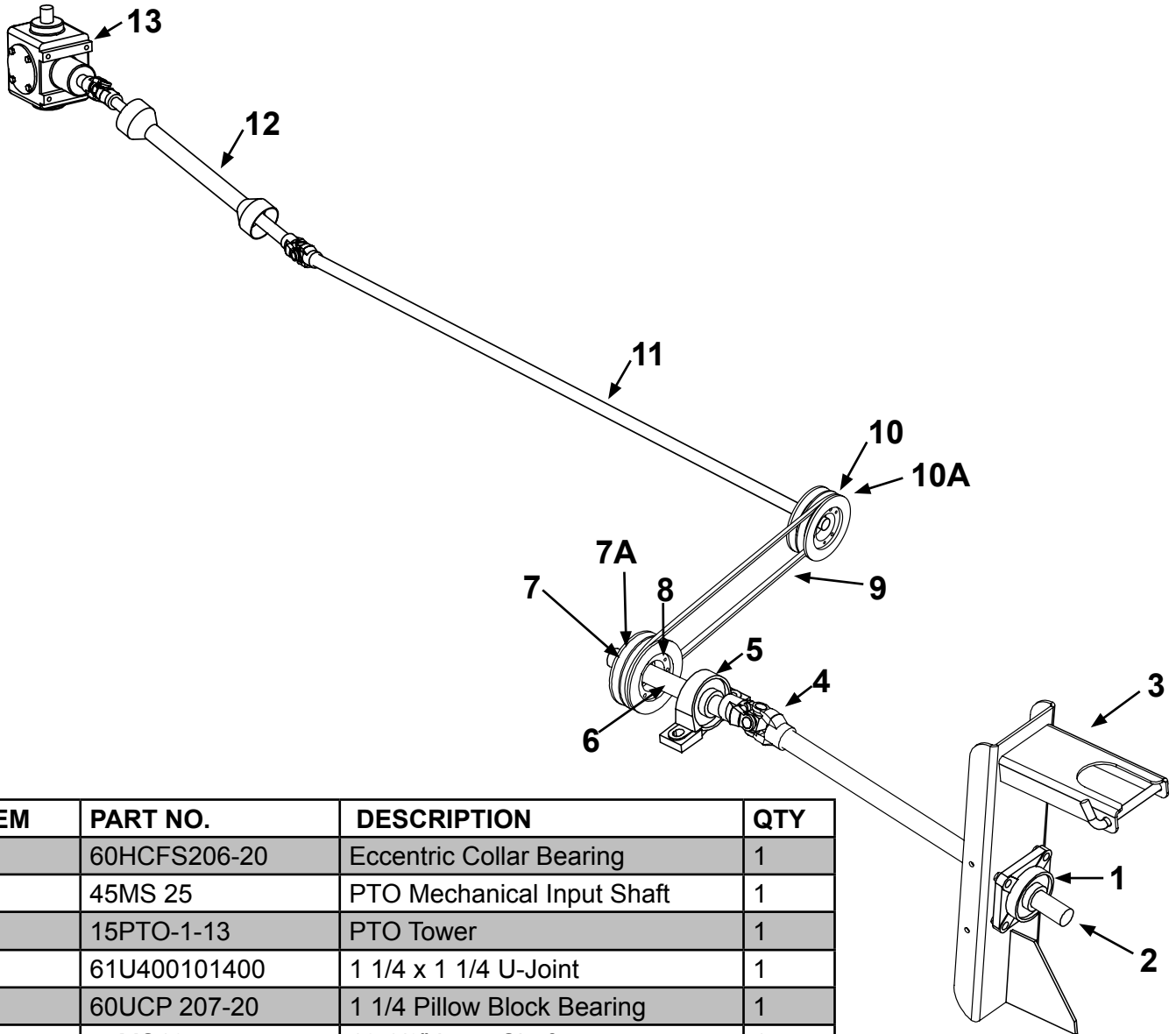

ITEM	PART NO.	DESCRIPTION	QTY
1.	60HCFS206-20	Eccentric Collar Bearing	1
2.	45MS 25	PTO Mechanical Input Shaft	1
3.	15PTO-1-13	PTO Tower	1
4.	61U400101400	1 1/4 x 1 1/4 U-Joint	1
5.	60UCP 207-20	1 1/4 Pillow Block Bearing	1
6.	45MS10	10 1/2" Input Shaft	1
7.	622B60 SDS	Pulley 540 RPM	1
7A.	622B46 SDS	Pulley 1000 RPM	1
8.	63SDS5125	1 1/4 Bushing	2
9.	68B61	Drive Belt	2
10.	622B46 SDS	Pulley 1000 RPM	1
10A.	622B60 SDS	Pulley 540 RPM	1
11.	Call Dealer	Main Driveline	1
12.	64PTO7102071	#2 PTO Driveline	1
13.	70PTF942-L	Gearbox - See Separate Diagram	1

ASSEMBLY IDENTIFICATION

Liberty Pull-Type

C: FRONT ROLLER COMPONENTS

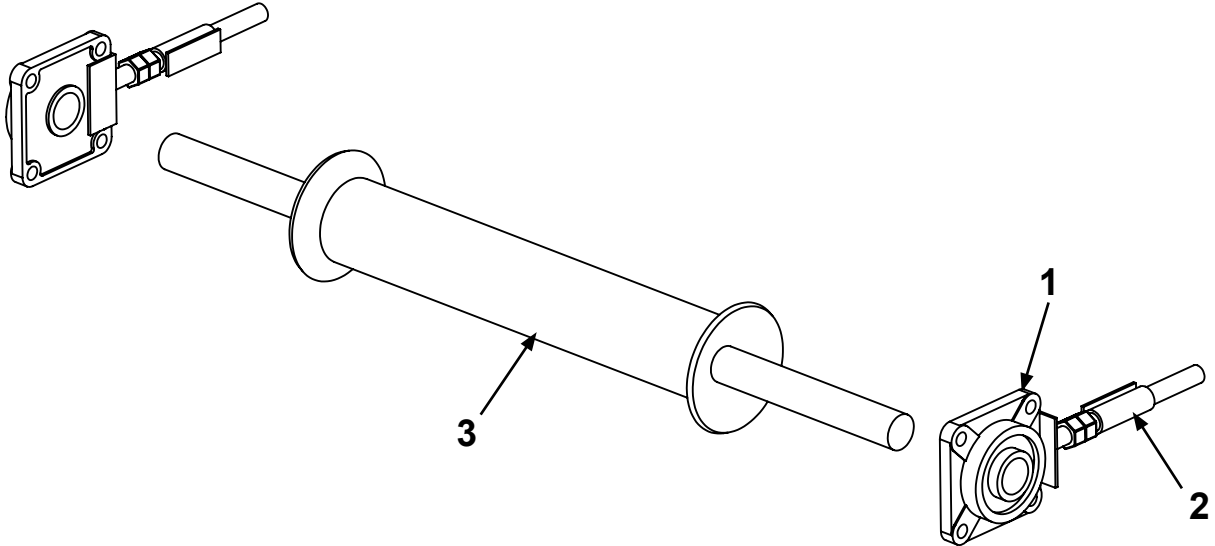

ITEM	PART NO.	DESCRIPTION	QTY
1.	60UCF208-24	1 1/2" 4-Bolt Flange	2
2A.	42 FRAZ	Adjusting Screw (Stainless)	2
2B.	42 FRAZ	Adjusting Screw (Zinc)	2

FRONT ROLLER - Order By Chain Size and Type			
ITEM	PART NO.	DESCRIPTION	QTY
3.	42 FRM 16	16" Mesh Chain	1
	42 FRM 18	18" Mesh Chain	1
	42 FRM 20	20" Mesh Chain	1
	Call with Serial #	24" Bar Chain	1

MESH CHAIN	CONNECTOR PINS
16" - 41 MC1116	41 MC 16 SP
18" - 41 MC1118	41 MC 18 SP
20" - 41 MC1120	41 MC 20 SP
24" BAR - Call with Serial #	

*NOTE: To replace entire chain, order 22' (hopper length x2, plus 2 feet).

ASSEMBLY IDENTIFICATION

Liberty Pull-Type

D: TORSION FLEX AXLE

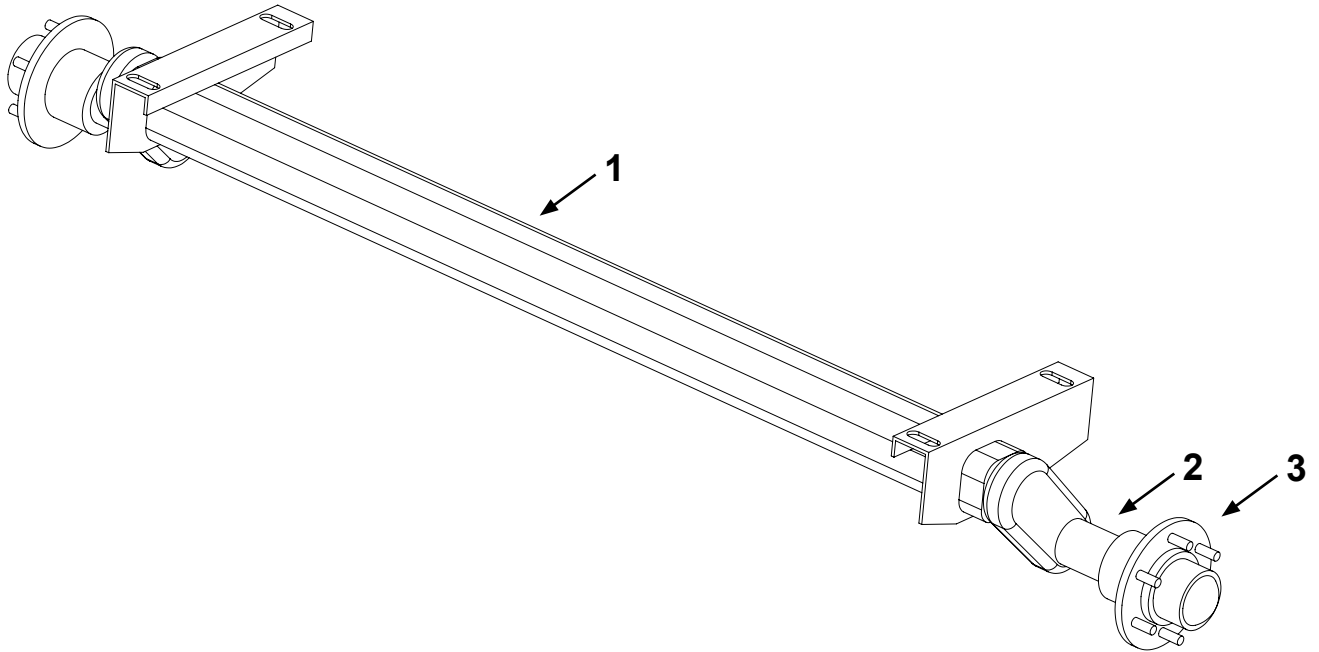

NON BRAKE TORSION FLEX AXLES - 45°			
ITEM	PART NO.	DESCRIPTION	QTY
1.	21AXBB7700224	7K Axle Assembly 6 Bolt	1
	21AXBB7101181	10K Axle Assembly 8 Bolt	1

BRAKE EQUIPPED AXLES			
ITEM	PART NO.	DESCRIPTION	QTY
	21AXBB7101302 H	10K Brake Axle Assembly 8 Bolt	1

ITEM	PART NO.	DESCRIPTION
2.	7K / 10K Spindle	See Diagram D1.
3.	7K Hub / 10K Hub	Diagram D1. / Diagram D2.

ASSEMBLY IDENTIFICATION

Liberty Pull-Type

D1: 7,000 LB (7K) HUB ASSEMBLY 22AX3160340A (6 BOLT) - NO SPINDLE

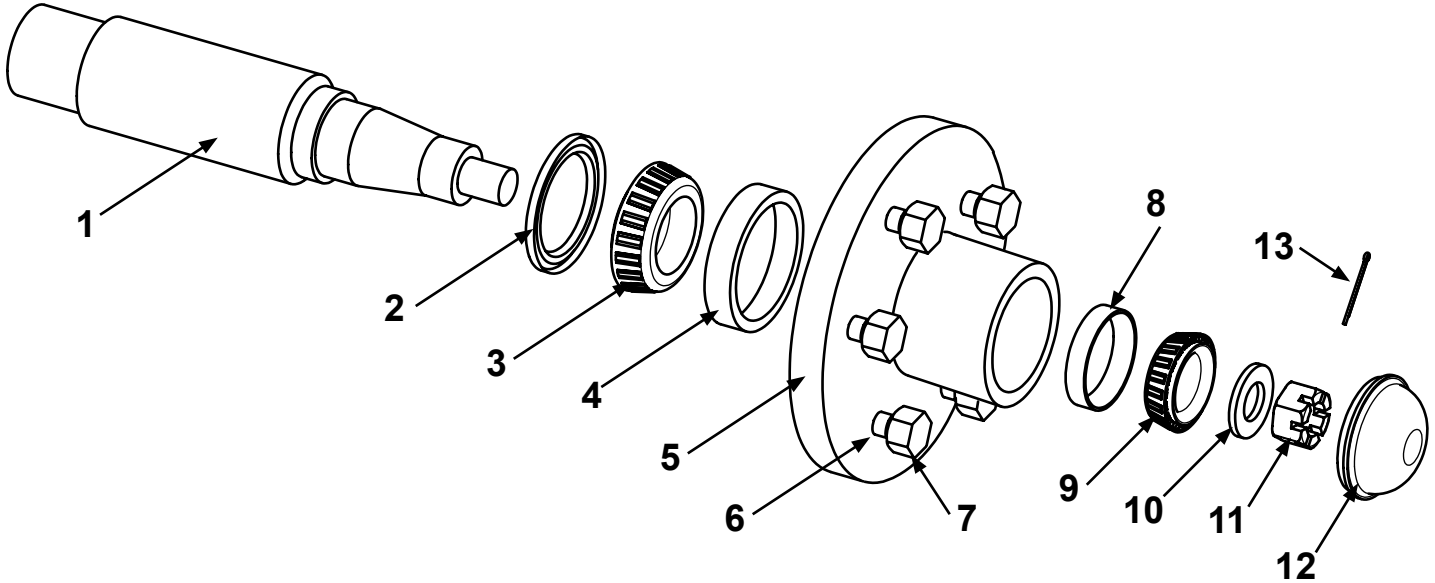

ITEM	PART NO.	DESCRIPTION	QTY
1.	22AXS-3500F	7K Spindle Shaft	1
2.	22AXSL-200	7K Oil Seal	1
3.	22AX501349	7K Inner Bearing	1
4.	22AX501310	7K Inner Race	1
5.	22AX3160340	7K 6 Lug Hub Only	1
6.	22AXB0250195	Press-in Stud	1
7.	22AXB0190032	Lug Nut	1
8.	22AX67010	7K Outer Race	1
9.	22AX67048	7K Outer Bearing	1
10.	22AXSW-1000	7K Axle Washer	1
11.	22AXSN-1000	7K Axle Nut	1
12.	22AX1604	7K Dust Cap	1
13.	22AXSCP-100	7K Cotter Pin	1

ASSEMBLY IDENTIFICATION

Liberty Pull-Type

D2: 10,000 LB (10K) HUB ASSEMBLY 22AX3160424A (8 BOLT) - NO SPINDLE

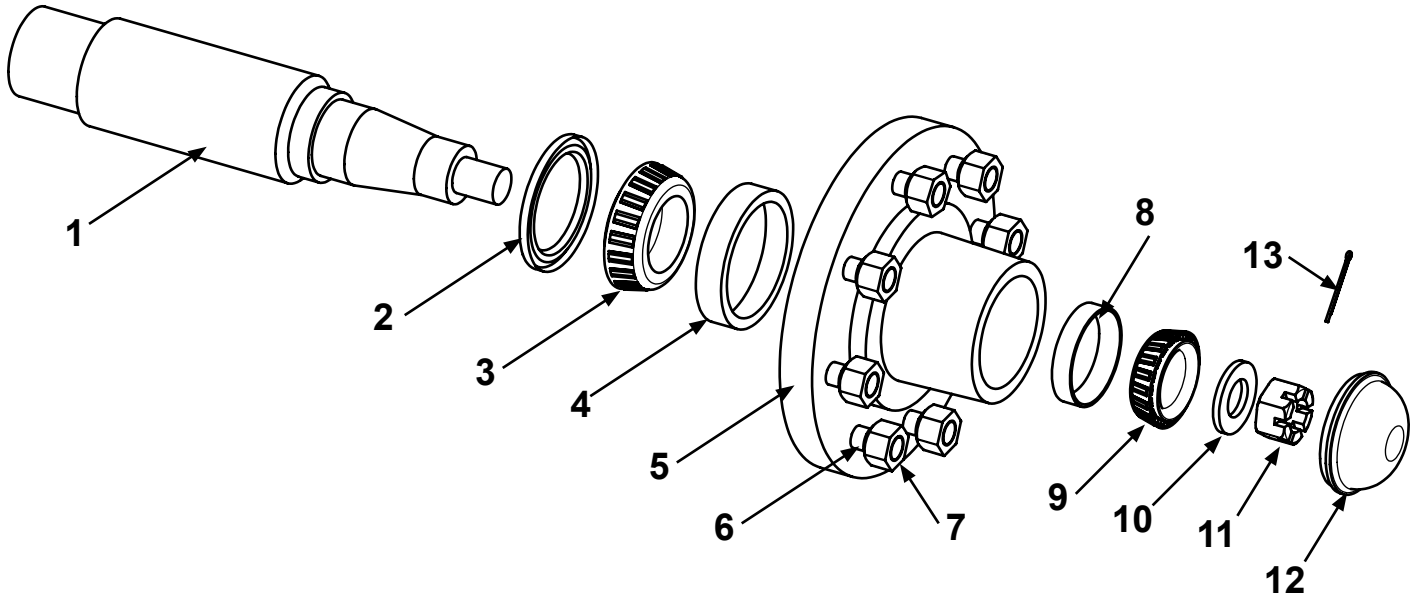

ITEM	PART NO.	DESCRIPTION	QTY
1.	22AXS-6000F	10K Spindle Shaft	1
2.	22AXSL-275	10K Oil Seal (CR27394)	1
3.	22AX506849	10K Inner Bearing	1
4.	22AX506810X	10K Inner Race	1
5.	22AX3160424	10K 8 Lug Hub Only	1
6.	22AXST-625	5/8" x 18-90 Press-in Stud	1
7.	22AXSTN-629	5/8" x 18-90 Lug Nut	1
8.	22AX501310	10K Outer Race	1
9.	22AX501349	10K Outer Bearing	1
10.	22AXSW-1001	10K Axle Washer	1
11.	22AXSN-1001	10K Axle Nut	1
12.	22AX1609	10K Dust Cap	1
13.	22AXSCP-102	10K Cotter Pin	1

ASSEMBLY IDENTIFICATION

Liberty Pull-Type

D3: 12,000 LB (12K) HUB ASSEMBLY 22AXBF2891300A (10 BOLT) - NO SPINDLE

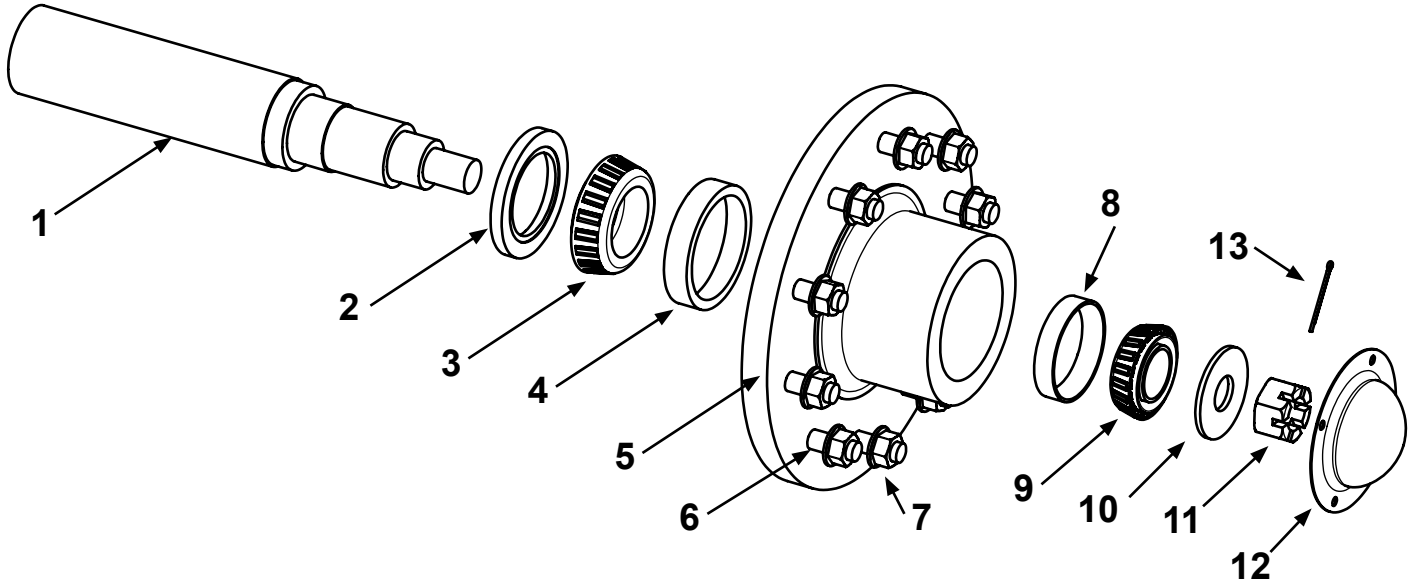

ITEM	PART NO.	DESCRIPTION	QTY
1.	22AXBB281309	12K Spindle Shaft	1
2.	22AXBB906497	12K Oil Seal 2	1
3.	22AXBB910333	12K Inner Bearing	1
4.	22AXBB910331	12K Inner Race	1
5.	22AXBF2891300	12K 10 Lug Hub Only	1
6.	22AXBB13564	12K Press in Stud	1
7.	22AXBB913571	12K Flanged Nut	1
8.	22AXBB910332	12K Outer Race	1
9.	22AXBB910334	12K Outer Bearing	1
10.	22AXBB913632	12K Axle Washer	1
11.	22AXBB913571	12K Axle Nut	1
12.	22AXBB909983	12K Dust Cap	1
13.	22AXSCP-103	12K Cotter Pin	1

ASSEMBLY IDENTIFICATION

Liberty Pull-Type

E: REAR ROLLER COMPONENTS

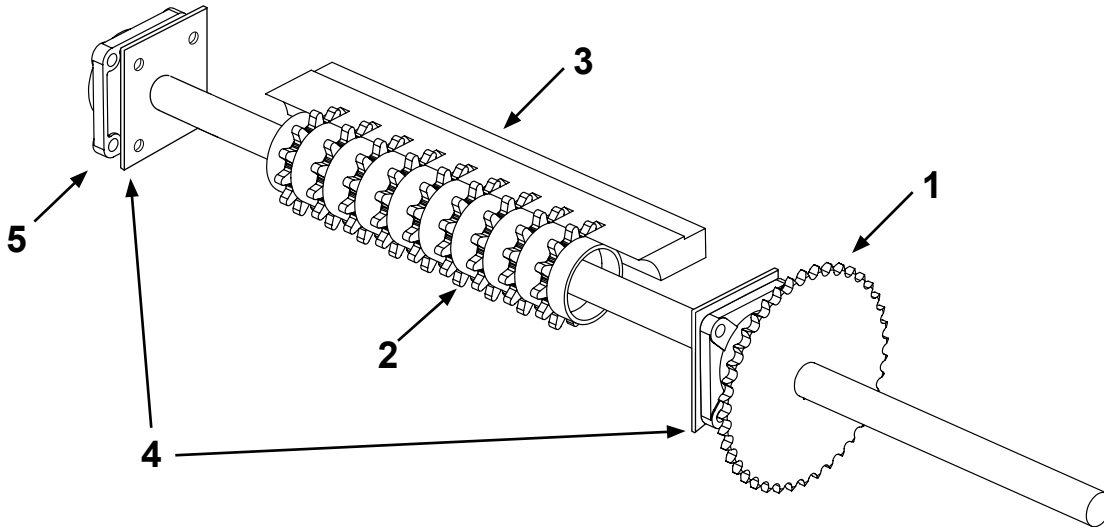

ITEM	PART NO.	DESCRIPTION	QTY
1.	676013540-1538	40 Tooth Drive Sprocket	1

REAR ROLLERS - Order by Chain Size

ITEM	PART NO.	DESCRIPTION	QTY
2.	42RRM16TP	For 16" Mesh Chain	1
2.	42RRM18TP	For 18" Mesh Chain	1
2.	42 RRM20TP	For 20" Mesh Chain	1
2.			1

COMBS - Order by Chain Size

ITEM	PART NO.	DESCRIPTION	QTY
3.	42C16	16" Comb	1
3.	42C18	18" Comb	1
3.	42C20	20" Comb	1

ITEM	PART NO.	DESCRIPTION	QTY
4.	89 POLYSQUARES	Poly Squares 6.5 x 6.5	2
5.	60UCF208-24	1 1/2" Flange Bearing	2

ASSEMBLY IDENTIFICATION

Liberty Pull-Type

TIRES

Liberty Tires							
Suspension	Tires	Wheels	Hubs				
7K Torsion	12.5 x 15	15 x 10	6 Lug				
10K Torsion	16.5 x 16.1	W14C x 16.1	8 Lug				
10 Ton W / B	16.5 x 16.1	W14C x 16.1	8 Lug				
14 Ton W / B	21.5 x 16.1	W16C x 16.1	10 Lug				

*Most common packages are listed above

*Proper identification can be made through calling the factory with your product serial number

ASSEMBLY IDENTIFICATION

Liberty Pull-Type

F: HYDRAULIC SPINNER SYSTEM COMPONENTS (1 OF 2)

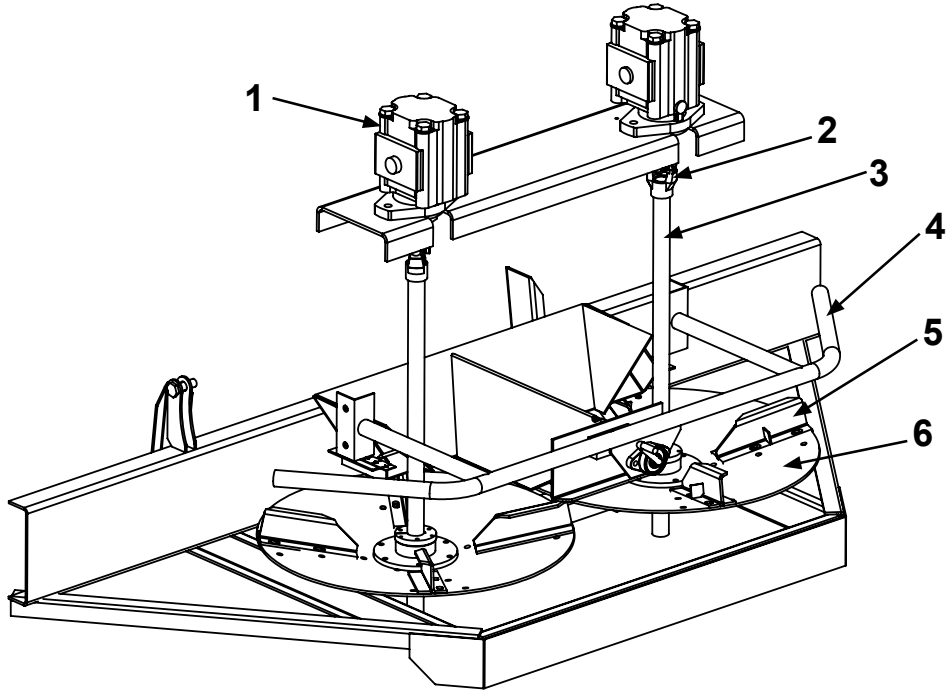

ITEM	PART NO.	DESCRIPTION	QTY
1.	3121SDM15	1.5" Spinner Motor	2
	31M2100SK152025	Seal Kit	1
	30Q1956-4	Seal Installation Tool. Required to properly install new motor pressure seal.	1
2.	61U183010293	U-Joint	2
3.	45FHMS28	Shaft	2
4A.	51SG-C	Guard Rail (Carbon)	1
4B.	51SG-S	Guard Rail (Stainless)	1

5. FINS

Carbon		Stainless	
51FT75MC-R	Carbon 7.5" Right	51FT75MS-R	Stainless 7.5" Right
51FT75MC-L	Carbon 7.5" Left	51FT75MS-L	Stainless 7.5" Left
51FT9MC-R	Carbon 9" Right	51FT9MS-R	Stainless 9" Right
51FT9MC-L	Carbon 9" Left	51FT9MS-L	Stainless 9" Left

6. DISC ASSEMBLIES

Carbon		Stainless	
50MS24CSA-RH	Carbon 24" Right	50MS24SSA-RH	Stainless 24" Right
50MS24CSA-LH	Carbon 24" Left	50MS24SSA-LH	Stainless 24" Left

ASSEMBLY IDENTIFICATION

Liberty Pull-Type

F: HYDRAULIC SPINNER SYSTEM COMPONENTS (2 OF 2)

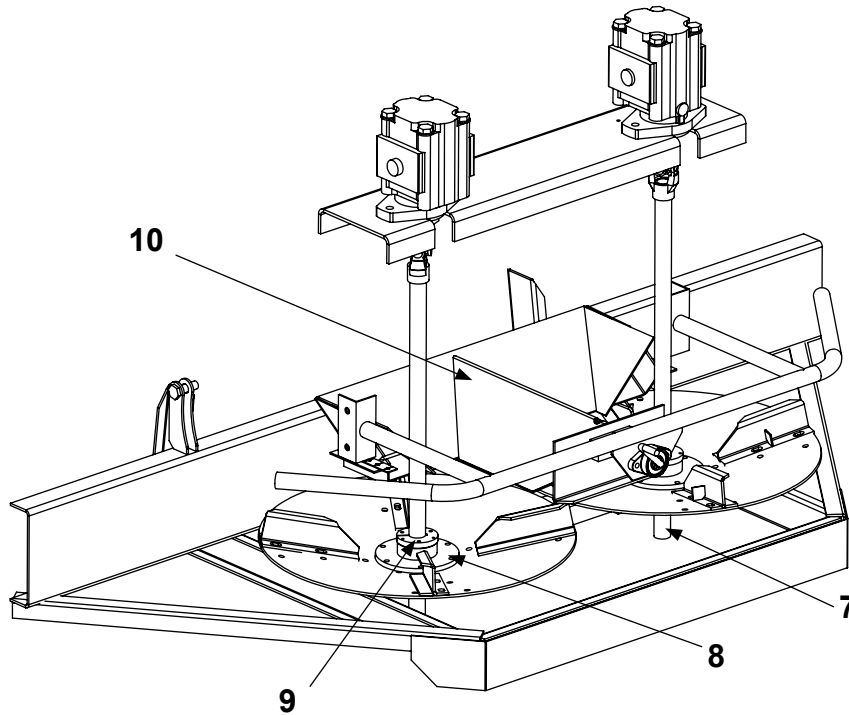

ITEM	PART NO.	DESCRIPTION	QTY
7.	60UCP207-20	1 1/4" Pillow Block	2
8.	58HP1B-FT	Hub	2
9.	50P1125	1 1/4" Locking Hub	2

FLOW DIVIDER AND COMPONENTS			
ITEM	PART NO.	DESCRIPTION	QTY
10.	52FFD200MS	Flow Divider	1
	18FD-MSI-C	Insert	1
	52TFD-1	Teflon Block	1
	60UCFL202-10	5/8" Bearing	1
	52FDH	Flow Divider Handle	1

ASSEMBLY IDENTIFICATION

Liberty Pull-Type

F: PTO DRIVEN SPINNER COMPONENTS

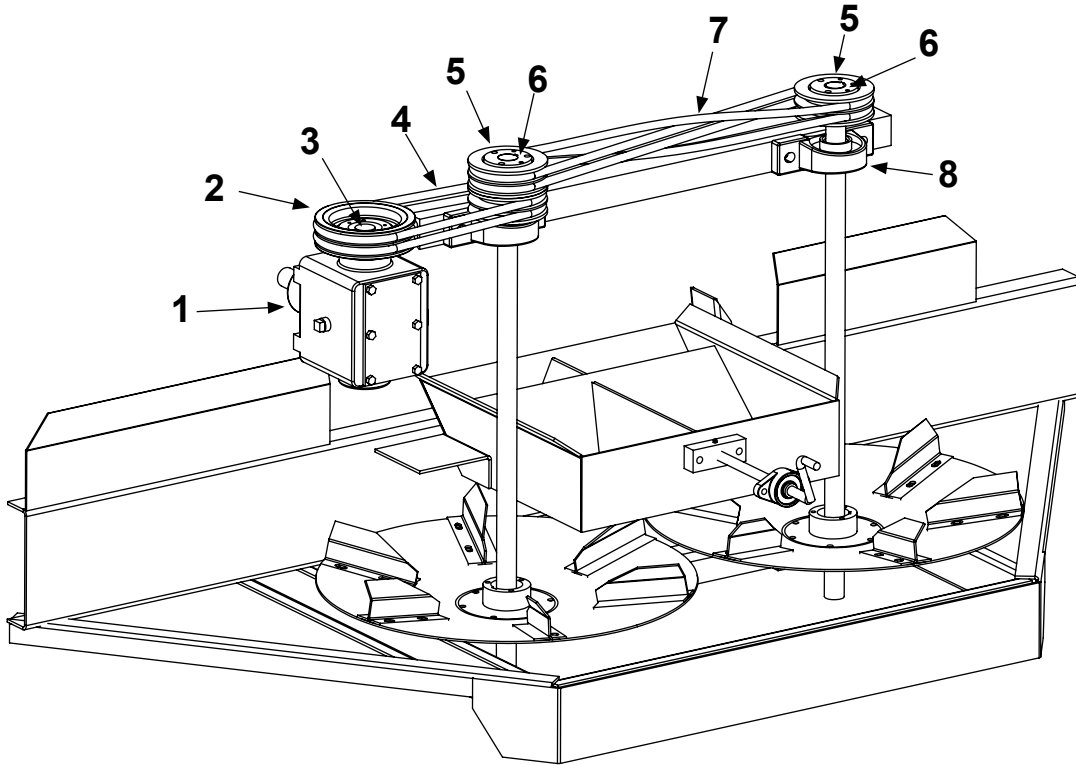

ITEM	PART NO.	DESCRIPTION	QTY
1.	70PTF942L	Gearbox - See Diagram	1
2.	622B60SDS	Pulley	1
3.	63SDS125	Taper Bushing / Lock Hub	4
4.	68B37	Drive Belt	2
5.	622B46SDS	Pulley	3
6.	63SDS125	Locking Hub	4
7.	68B63K	Kevlar Spinner Drive Belt	2
8.	60UCP2070-20	1 1/4" Pillow Block Bearing	4

NOTE: Fins, Shafts, and Flow Divider components can be found on Hydraulic Spinner System Components Section

ASSEMBLY IDENTIFICATION

Liberty Pull-Type

G: TWO SHAFT SPINNER GEARBOX (1 OF 2) 70PTF942

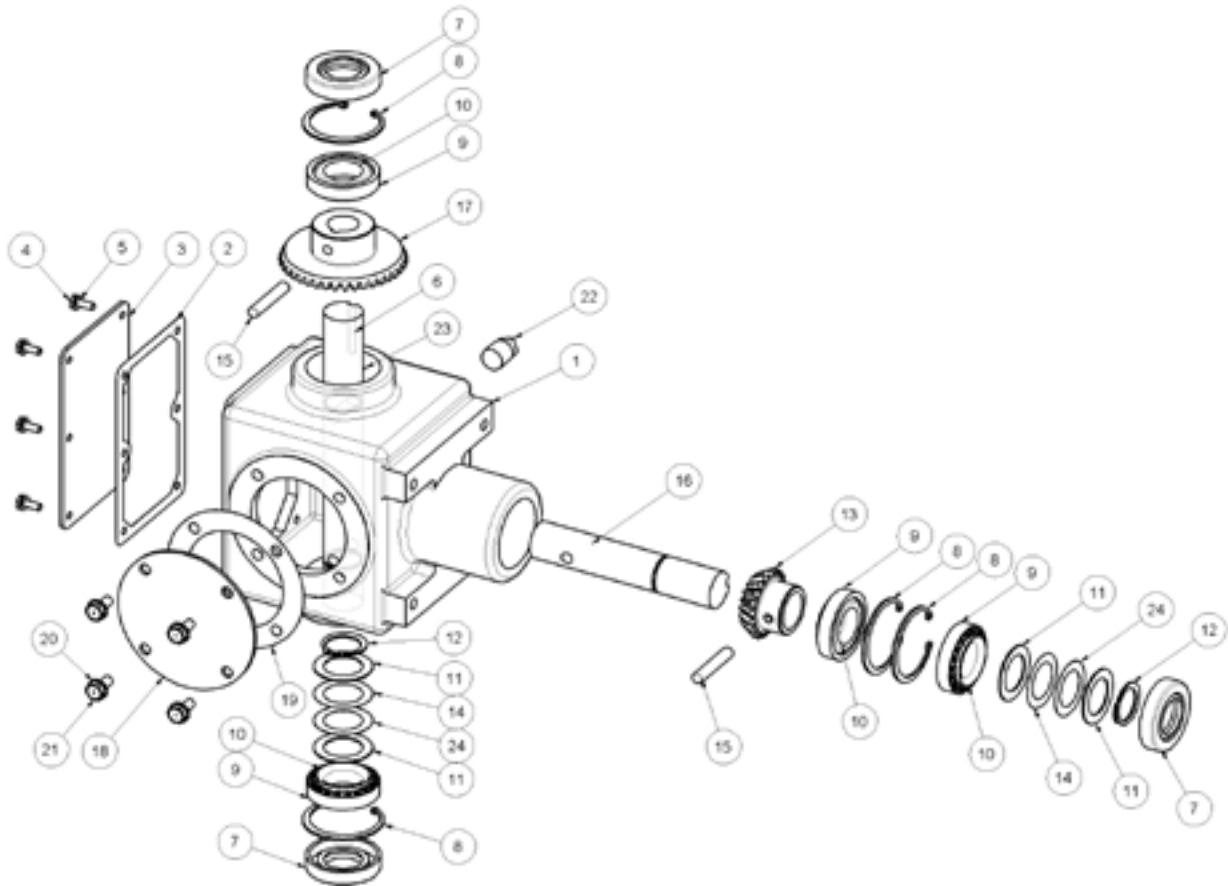

ITEM	PART NO.	DESCRIPTION	QTY
1.	70PTF-1A	LH Housing w/ Grease Fitting	1
2.	70PTF-3	Gasket, Top (Rectangle)	1
3.	70PTF-2A	Top Cover (Rectangle)	1
4.	70PTF-4	Cap Screws (1/4" x 3/4")	6
5.	70PTF-5	Split Lock Washers, 1/4"	6
6.	70PTF-6	Output Shaft (1-1/4" x 10-3/4")	1
7.	70PTF-11	Oil Seal	3
8.	70PTF-12	Retaining Ring, Large	4
9.	70PTF-10R16	Race	4
10.	70PTF-10C	Bearing	4
11.	70PTF-16	Washer / Spacer / Shim	4
12.	70PTF-13	Retaining Ring, Small	2

ASSEMBLY IDENTIFICATION

Liberty Pull-Type

G: TWO SHAFT SPINNER GEARBOX (2 OF 2) 70PTF942

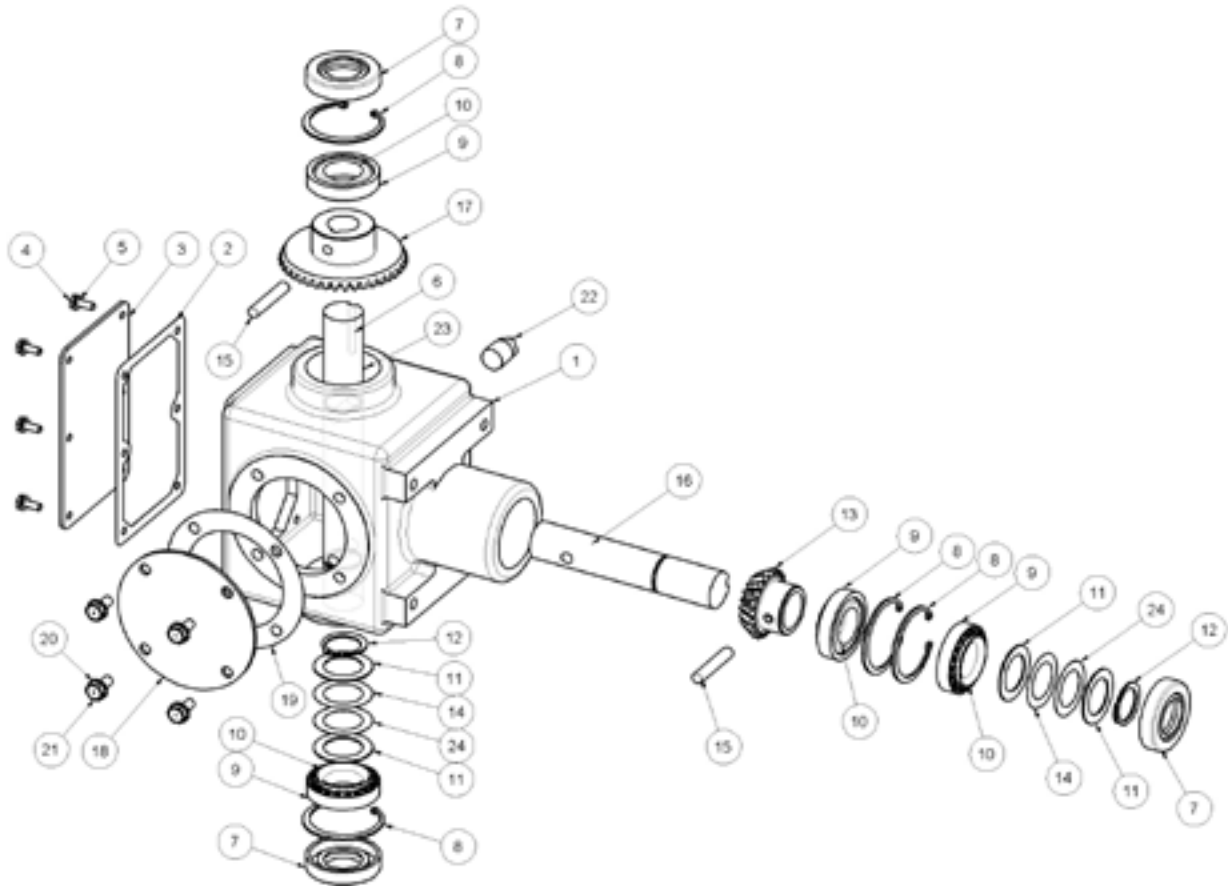

ITEM	PART NO.	DESCRIPTION	QTY
13.	70PTF-8P	Pinion gear	1
14.	70PTF-18A	Shim .005	2
15.	70PTF-9	#15 Roll Pin (2" x .385/.375)	2
16.	70PTF-7	Input Shaft (1-1/4" x 6-5/8")	1
17.	70PTF-8B	Gear	1
18.	70PTF-2B	Side Cover (Round)	1
19.	70PTF-19B	Side Gasket, Round .020	1
20.	70PTF-17	Lock Washer, Split (5/16")	1
21.	70PTF-15A	Cap Screw (5/16" x 1-1/2")	4
22.	70PTF-14	Pipe Plug	1
23.	70PTF-22	Grease Fitting	1
24.	70PTF-18B	Shim .010	2

ASSEMBLY IDENTIFICATION

Liberty Pull-Type

H: GROUND DRIVE COMPONENTS (1 OF 3)

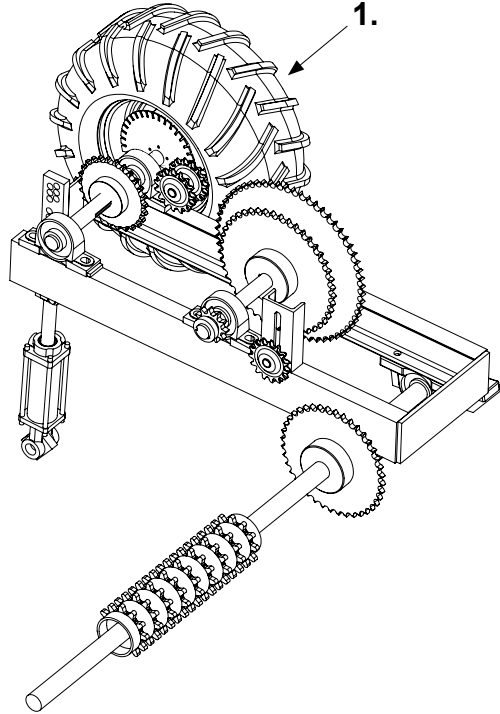

TIRES			
ITEM	PART NO.	DESCRIPTION	QTY
1.	25427820L	Cleated with Rim	1
	25GW43259	Smooth with Rim	1
	25GWH70040	20" Segmented	1
	25GWH70033	15" Segmented	1

METAL PRESS WHEEL			
ITEM	PART NO.	DESCRIPTION	QTY
1.	25 GWM	Metal Press Wheel	1

HUBS			
ITEM	PART NO.	DESCRIPTION	QTY
1.	25 GW-H4-A	4 Lug Hub	1
	25 GW-H5-A	5 Lug Hub	1

ASSEMBLY IDENTIFICATION

Liberty Pull-Type

H: GROUND DRIVE COMPONENTS (2 OF 3)

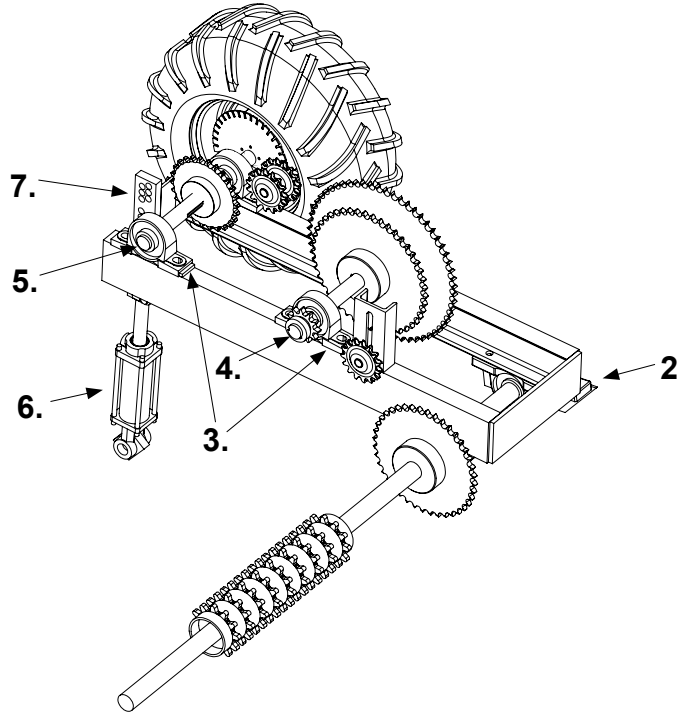

ITEM	PART NO.	DESCRIPTION	QTY
2.	60UCP208-24	1 1/2 Pillow Block	2
3.	60UCP207-20	1 1/4 Pillow Block	4
4.	25GWS-Sprockets	Sprocket Shaft	1
5.	25GWS-Drive	Drive Shaft	1
6.	362004TCB	Hydraulic Cylinder	1
7.	15GHC-M9-A	Adjustable Mount	
8.	253848272	Return Spring (not featured)	1

ASSEMBLY IDENTIFICATION

Liberty Pull-Type

H: GROUND DRIVE COMPONENTS (3 OF 3) - SPROCKETS AND CHAINS

ITEM	PART NO.	DESCRIPTION	QTY
1.	6760BS40-1538	40 Tooth Sprocket	1
2.	6760BS11-1225	11 Tooth Sprocket	2
3.	6760BS45-1225	45 Tooth Sprocket	1
4.	6760BS60-1225	60 Tooth Sprocket	1
5.	6760BS26-1225	26 Tooth Sprocket	1
6.	6760BS11-1225	11 Tooth Sprocket	1
7.	67AG 2417	Idler Sprocket	3

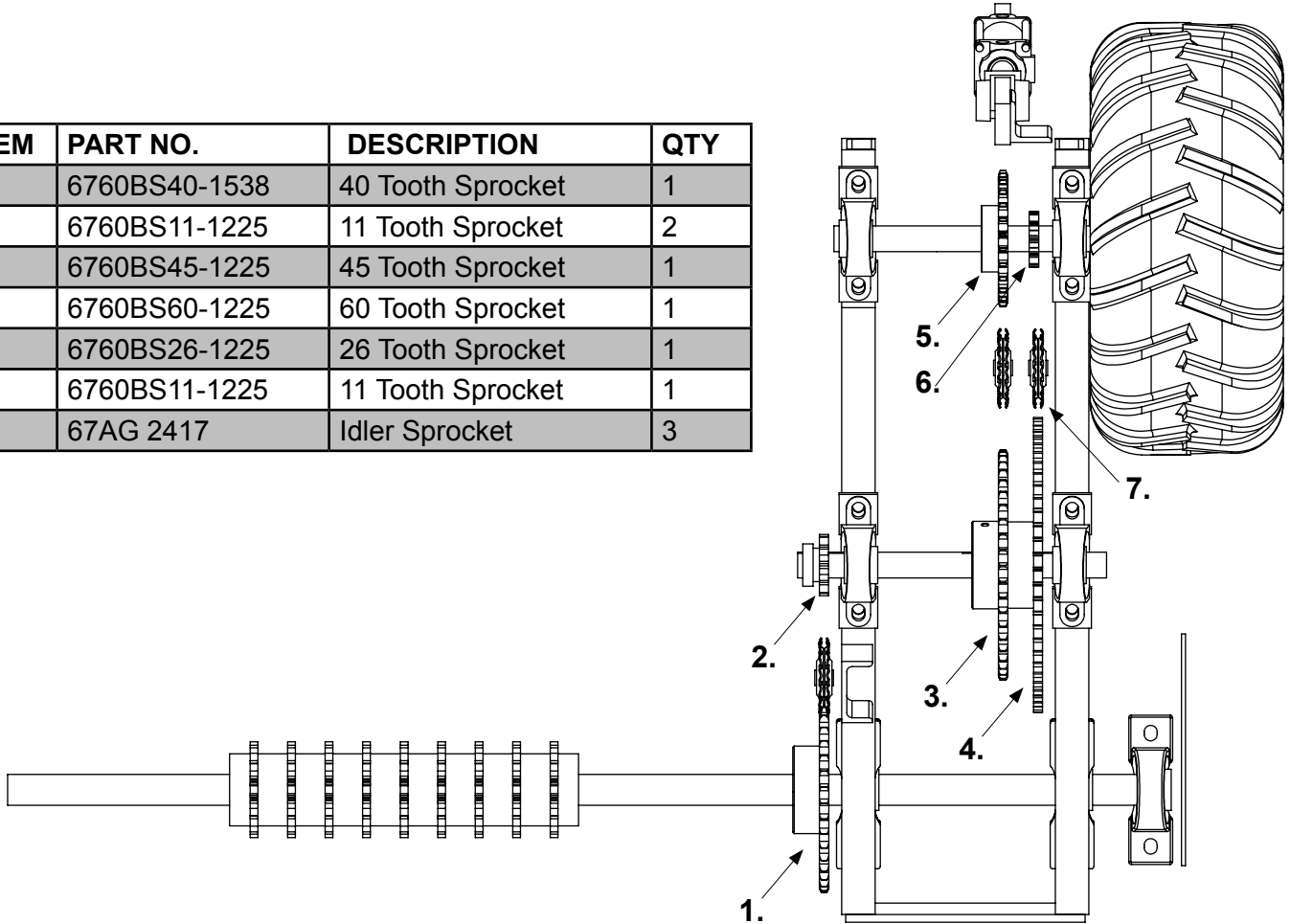

CHAIN - # 60 ROLLER - Carbon or Stainless	
PART NO.	DESCRIPTION
4160 - 1BLK	# 60 Chain - Carbon
4160 - 1SS	# 60 Chain - Stainless
4160 - 1CL	Master Link - Carbon
4160 - 1CLSS	Master Link - Stainless

ASSEMBLY IDENTIFICATION

Liberty Pull-Type

I: GATE COMPONENTS

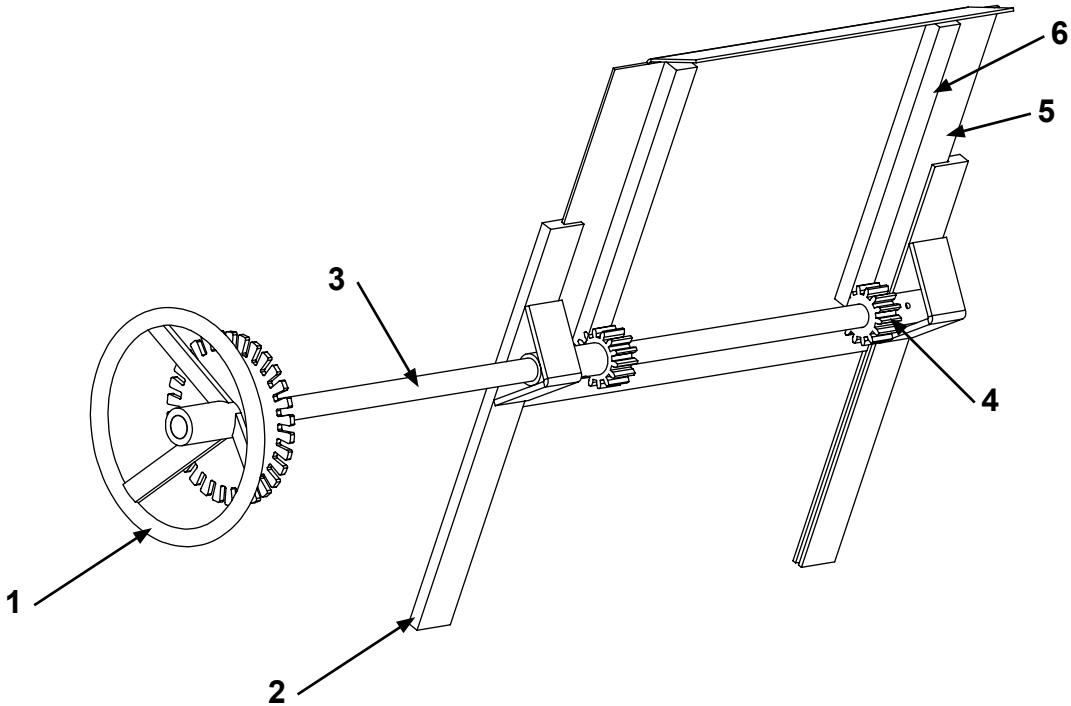

ITEM	PART NO.	DESCRIPTION	QTY
1.	53GWB-7	Gate Wheel	1
2.	53GS	Gate Slide (Stainless)	2
3.	53GSS	Gate Shaft (Stainless)	1
4.	53GWS-2	Spur Gear	1
5.	53RG-2	Gate (Stainless)	1
6.	53GWS-3	Gear Rack	2
7.	53GGFT	Gate Gauge	1
8.	53RG-15	Gate with Gear Rack	1

ASSEMBLY IDENTIFICATION

Liberty Pull-Type

J. SPINNER MOTOR 3121SDM15

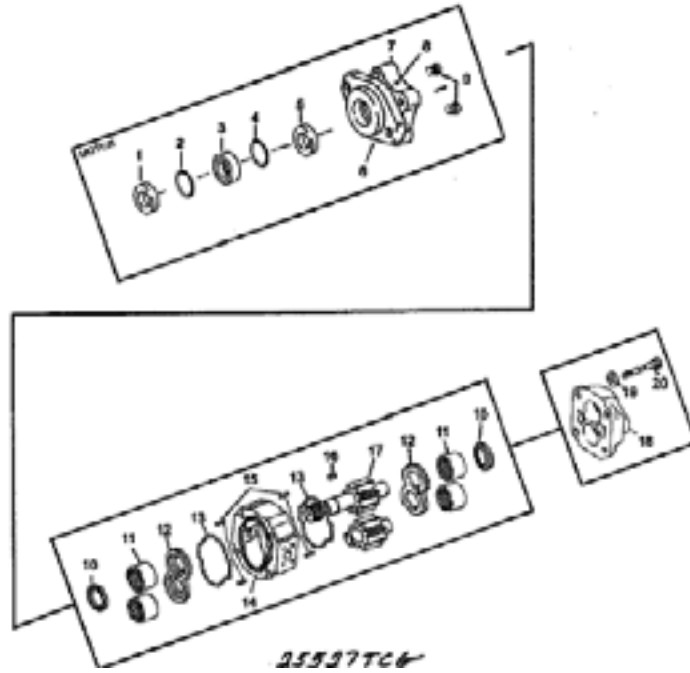

ITEM	PART NO.	DESCRIPTION	QTY
1.	25527TCG	Grease Seal	1
2.	W023-206	Snap Ring	1
3.	MZ-0961	Tell-Tale Seal Retainer	1
4.	K-2995-109	Seal Retainer O-Ring	1
5.	W62-49-9	Shaft Seal	1
6.		1/8" NPT Grease Fitting Hole	
7.		2-Bolt-B Shaft End Cover (SEC)	1
8.	W0-17	Pipe Plug 1/4" NPT for (SEC)	1
9.	L-0280-K	Check Valve Assembly	2
10.	KA-0558-1XS	Ring Seal	2
11.	X-0921	Roller Bearing	4
12.	ZZ-0947-TC	Thrust Plate	2
13.	K-2995-240	Gear Housing Gasket Seal	2
14.		Gear Housing	1
15.	280-1971-031	Dowel Pin	4
16.	W09-02	Shaft Key	1
17.		Gear Set	1
18.	592-00662	Port End Cover (PEC)	1
19.	W033-3	Washer 9/16"	4
20.		Hex Head Bolt	4

RATE CHARTS

Liberty Pull-Type

16" MESH CHAIN RATE CHART 60 / 30



APPLICATION RATE 16" MESH CHAIN

470 Wayside St. S.
Cornelia, GA 30531
Ph: (706) 778-2767
Fax: (706) 778-2787

Low Application Rate

High Application Rate

Sprocket Ratio - 11:60

Spread Swath **60 ft**

Sprocket Ratio - 26:45

Spread Swath **30 ft**

12	417	469	521	573	625	677	729	781	833	886	938	990	1042
11.5	399	449	499	549	599	649	699	749	799	849	899	949	998
11	382	430	478	525	573	621	669	716	764	812	860	907	955
10.5	365	410	456	501	547	593	638	684	729	775	820	866	912
10	347	391	434	478	521	564	608	651	695	738	781	825	868
9.5	330	371	412	454	495	536	577	619	660	701	742	784	825
9	313	352	391	430	469	508	547	586	625	664	703	742	781
8.5	295	332	369	406	443	480	517	553	590	627	664	701	738
8	278	313	347	382	417	451	486	521	556	590	625	660	695
7.5	260	293	326	358	391	423	456	488	521	553	586	619	651
7	243	273	304	334	365	395	425	456	486	517	547	577	608
6.5	226	254	282	310	339	367	395	423	451	480	508	536	564
6	208	234	260	287	313	339	365	391	417	443	469	495	521
5.5	191	215	239	263	287	310	334	358	382	406	430	454	478
5	174	195	217	239	260	282	304	326	347	369	391	412	434
4.5	156	176	195	215	234	254	273	293	313	332	352	371	391
4	139	156	174	191	208	226	243	260	278	295	313	330	347
3.5	122	137	152	167	182	198	213	228	243	258	273	289	304
3	104	117	130	143	156	169	182	195	208	221	234	247	260
2.5	87	98	109	119	130	141	152	163	174	184	195	206	217
2	69	78	87	96	104	113	122	130	139	148	156	165	174
1.5	52	59	65	72	78	85	91	98	104	111	117	124	130
1	35	39	43	48	52	56	61	65	69	74	78	82	87
	40	45	50	55	60	65	70	75	80	85	90	95	100

MATERIAL DENSITY (LBS PER CU. FT.)

12	2627	2955	3283	3612	3940	4268	4597	4925	5253	5582	5910	6239	6567
11.5	2517	2832	3147	3461	3776	4091	4405	4720	5035	5349	5664	5979	6293
11	2408	2709	3010	3311	3612	3913	4214	4515	4816	5117	5418	5719	6020
10.5	2298	2586	2873	3160	3448	3735	4022	4310	4597	4884	5171	5459	5746
10	2189	2463	2736	3010	3283	3557	3831	4104	4378	4652	4925	5199	5472
9.5	2080	2339	2599	2859	3119	3379	3639	3899	4159	4419	4679	4939	5199
9	1970	2216	2463	2709	2955	3201	3448	3694	3940	4186	4433	4679	4925
8.5	1861	2093	2326	2558	2791	3023	3256	3489	3721	3954	4186	4419	4652
8	1751	1970	2189	2408	2627	2846	3065	3283	3502	3721	3940	4159	4378
7.5	1642	1847	2052	2257	2463	2668	2873	3078	3283	3489	3694	3899	4104
7	1532	1724	1915	2107	2298	2490	2681	2873	3065	3256	3448	3639	3831
6.5	1423	1601	1779	1956	2134	2312	2490	2668	2846	3023	3201	3379	3557
6	1313	1478	1642	1806	1970	2134	2298	2463	2627	2791	2955	3119	3283
5.5	1204	1354	1505	1655	1806	1956	2107	2257	2408	2558	2709	2859	3010
5	1094	1231	1368	1505	1642	1779	1915	2052	2189	2326	2463	2599	2736
4.5	985	1108	1231	1354	1478	1601	1724	1847	1970	2093	2216	2339	2463
4	876	985	1094	1204	1313	1423	1532	1642	1751	1861	1970	2080	2189
3.5	766	862	958	1053	1149	1245	1341	1437	1532	1628	1724	1820	1915
3	657	739	821	903	985	1067	1149	1231	1313	1395	1478	1560	1642
2.5	547	616	684	752	821	889	958	1026	1094	1163	1231	1300	1368
2	438	493	547	602	657	711	766	821	876	930	985	1040	1094
1.5	328	369	410	451	493	534	575	616	657	698	739	780	821
1	219	246	274	301	328	356	383	410	438	465	493	520	547
	40	45	50	55	60	65	70	75	80	85	90	95	100

MATERIAL DENSITY (LBS PER CU. FT.)

1) Locate Material Weight per Cubic Foot at the bottom of the desired chart.

NOTE: If the weight per cubic foot is not known, weigh one gallon of material and multiply by 7.5. This will give you approximate material weight per cubic foot.
(5 gal. X 1.5 = Approx. 1 cubic foot)

2) Look up the column vertically to find the amount of Material you want to Spread per Acre.

3) Move left across the row to locate the Gate Setting required for your application.

CAUTION: This Chart is CORRECT only for the specific type of spreader noted at the top of this chart, and for the application rate (High or Low) and swath as noted.



RATE CHARTS

Liberty Pull-Type

16" MESH CHAIN RATE CHART 80 / 60



APPLICATION RATE 16" MESH CHAIN

470 Wayside St. S.
Cornelia, GA 30531
Ph: (706) 778-2767
Fax: (706) 778-2787

Low Application Rate

High Application Rate

Sprocket Ratio - 11:60

Spread Swath **80 ft**

Sprocket Ratio - 26:45

Spread Swath **60 ft**

GATE SETTING	12	313	352	391	430	469	508	547	586	625	664	703	742	781
	11.5	300	337	374	412	449	487	524	562	599	637	674	711	749
	11	287	322	358	394	430	466	501	537	573	609	645	680	716
	10.5	273	308	342	376	410	444	479	513	547	581	615	650	684
	10	260	293	326	358	391	423	456	488	521	553	586	619	651
	9.5	247	278	309	340	371	402	433	464	495	526	557	588	619
	9	234	264	293	322	352	381	410	440	469	498	527	557	586
	8.5	221	249	277	304	332	360	387	415	443	470	498	526	553
	8	208	234	260	287	313	339	365	391	417	443	469	495	521
	7.5	195	220	244	269	293	317	342	366	391	415	440	464	488
	7	182	205	228	251	273	296	319	342	365	387	410	433	456
	6.5	169	190	212	233	254	275	296	317	339	360	381	402	423
	6	156	176	195	215	234	254	273	293	313	332	352	371	391
	5.5	143	161	179	197	215	233	251	269	287	304	322	340	358
	5	130	147	163	179	195	212	228	244	260	277	293	309	326
	4.5	117	132	147	161	176	190	205	220	234	249	264	278	293
4	104	117	130	143	156	169	182	195	208	221	234	247	260	
3.5	91	103	114	125	137	148	160	171	182	194	205	217	228	
3	78	88	98	107	117	127	137	147	156	166	176	186	195	
2.5	65	73	81	90	98	106	114	122	130	138	147	155	163	
2	52	59	65	72	78	85	91	98	104	111	117	124	130	
1.5	39	44	49	54	59	63	68	73	78	83	88	93	98	
1	26	29	33	36	39	42	46	49	52	55	59	62	65	
		40	45	50	55	60	65	70	75	80	85	90	95	100

MATERIAL DENSITY (LBS PER CU. FT.)

GATE SETTING	12	1313	1478	1642	1806	1970	2134	2298	2463	2627	2791	2955	3119	3283
	11.5	1259	1416	1573	1731	1888	2045	2203	2360	2517	2675	2832	2989	3147
	11	1204	1354	1505	1655	1806	1956	2107	2257	2408	2558	2709	2859	3010
	10.5	1149	1293	1437	1580	1724	1867	2011	2155	2298	2442	2586	2729	2873
	10	1094	1231	1368	1505	1642	1779	1915	2052	2189	2326	2463	2599	2736
	9.5	1040	1170	1300	1430	1560	1690	1820	1950	2080	2209	2339	2469	2599
	9	985	1108	1231	1354	1478	1601	1724	1847	1970	2093	2216	2339	2463
	8.5	930	1047	1163	1279	1395	1512	1628	1744	1861	1977	2093	2209	2326
	8	876	985	1094	1204	1313	1423	1532	1642	1751	1861	1970	2080	2189
	7.5	821	923	1026	1129	1231	1334	1437	1539	1642	1744	1847	1950	2052
	7	766	862	958	1053	1149	1245	1341	1437	1532	1628	1724	1820	1915
	6.5	711	800	889	978	1067	1156	1245	1334	1423	1512	1601	1690	1779
	6	657	739	821	903	985	1067	1149	1231	1313	1395	1478	1560	1642
	5.5	602	677	752	828	903	978	1053	1129	1204	1279	1354	1430	1505
	5	547	616	684	752	821	889	958	1026	1094	1163	1231	1300	1368
	4.5	493	554	616	677	739	800	862	923	985	1047	1108	1170	1231
4	438	493	547	602	657	711	766	821	876	930	985	1040	1094	
3.5	383	431	479	527	575	622	670	718	766	814	862	910	958	
3	328	369	410	451	493	534	575	616	657	698	739	780	821	
2.5	274	308	342	376	410	445	479	513	547	581	616	650	684	
2	219	246	274	301	328	356	383	410	438	465	493	520	547	
1.5	164	185	205	226	246	267	287	308	328	349	369	390	410	
1	109	123	137	150	164	178	192	205	219	233	246	260	274	
		40	45	50	55	60	65	70	75	80	85	90	95	100

MATERIAL DENSITY (LBS PER CU. FT.)

1) Locate Material Weight per Cubic Foot at the bottom of the desired chart.

NOTE: If the weight per cubic foot is not known, weigh one gallon of material and multiply by 7.5. This will give your approximate material weight per cubic foot.
(5 gal. X 1.5 = Approx. 1 cubic foot)

2) Look up the column vertically to find the amount of Material you want to Spread per Acre.

3) Move left across the row to locate the Gate Setting required for your application.

CAUTION: This Chart is CORRECT only for the specific type of spreader noted at the top of this chart, and for the application rate (High or Low) and swath as noted.



RATE CHARTS

Liberty Pull-Type

18" MESH CHAIN RATE CHART 60 / 30



APPLICATION RATE 18" MESH CHAIN

470 Wayside St. S.
Cornelia, GA 30531
Ph: (706) 778-2767
Fax: (706) 778-2787

Low Application Rate

High Application Rate

Sprocket Ratio - 11:60

Spread Swath **60 ft**

Sprocket Ratio - 26:45

Spread Swath **30 ft**

12	454	510	567	624	680	737	794	850	907	964	1020	1077	1134
11.5	435	489	543	598	652	706	761	815	869	924	978	1032	1087
11	416	468	520	572	624	676	728	779	831	883	935	987	1039
10.5	397	446	496	546	595	645	694	744	794	843	893	942	992
10	378	425	472	520	567	614	661	709	756	803	850	898	945
9.5	359	404	449	494	539	583	628	673	718	763	808	853	898
9	340	383	425	468	510	553	595	638	680	723	765	808	850
8.5	321	361	402	442	482	522	562	602	642	683	723	763	803
8	302	340	378	416	454	491	529	567	605	642	680	718	756
7.5	283	319	354	390	425	461	496	531	567	602	638	673	709
7	265	298	331	364	397	430	463	496	529	562	595	628	661
6.5	246	276	307	338	368	399	430	461	491	522	553	583	614
6	227	255	283	312	340	368	397	425	454	482	510	539	567
5.5	208	234	260	286	312	338	364	390	416	442	468	494	520
5	189	213	236	260	283	307	331	354	378	402	425	449	472
4.5	170	191	213	234	255	276	298	319	340	361	383	404	425
4	151	170	189	208	227	246	265	283	302	321	340	359	378
3.5	132	149	165	182	198	215	231	248	265	281	298	314	331
3	113	128	142	156	170	184	198	213	227	241	255	269	283
2.5	94	106	118	130	142	154	165	177	189	201	213	224	236
2	76	85	94	104	113	123	132	142	151	161	170	180	189
1.5	57	64	71	78	85	92	99	106	113	120	128	135	142
1	38	43	47	52	57	61	66	71	76	80	85	90	94
	40	45	50	55	60	65	70	75	80	85	90	95	100

MATERIAL DENSITY (LBS PER CU. FT.)

12	2859	3216	3573	3930	4288	4645	5002	5360	5717	6074	6432	6789	7146
11.5	2739	3082	3424	3767	4109	4452	4794	5136	5479	5821	6164	6506	6849
11	2620	2948	3275	3603	3930	4258	4586	4913	5241	5568	5896	6223	6551
10.5	2501	2814	3127	3439	3752	4064	4377	4690	5002	5315	5628	5940	6253
10	2382	2680	2978	3275	3573	3871	4169	4466	4764	5062	5360	5657	5955
9.5	2263	2546	2829	3112	3394	3677	3960	4243	4526	4809	5092	5375	5657
9	2144	2412	2680	2948	3216	3484	3752	4020	4288	4556	4824	5092	5360
8.5	2025	2278	2531	2784	3037	3290	3543	3796	4050	4303	4556	4809	5062
8	1906	2144	2382	2620	2859	3097	3335	3573	3811	4050	4288	4526	4764
7.5	1787	2010	2233	2457	2680	2903	3127	3350	3573	3796	4020	4243	4466
7	1667	1876	2084	2293	2501	2710	2918	3127	3335	3543	3752	3960	4169
6.5	1548	1742	1935	2129	2323	2516	2710	2903	3097	3290	3484	3677	3871
6	1429	1608	1787	1965	2144	2323	2501	2680	2859	3037	3216	3394	3573
5.5	1310	1474	1638	1801	1965	2129	2293	2457	2620	2784	2948	3112	3275
5	1191	1340	1489	1638	1787	1935	2084	2233	2382	2531	2680	2829	2978
4.5	1072	1206	1340	1474	1608	1742	1876	2010	2144	2278	2412	2546	2680
4	953	1072	1191	1310	1429	1548	1667	1787	1906	2025	2144	2263	2382
3.5	834	938	1042	1146	1251	1355	1459	1563	1667	1772	1876	1980	2084
3	715	804	893	983	1072	1161	1251	1340	1429	1519	1608	1697	1787
2.5	596	670	744	819	893	968	1042	1117	1191	1265	1340	1414	1489
2	476	536	596	655	715	774	834	893	953	1012	1072	1131	1191
1.5	357	402	447	491	536	581	625	670	715	759	804	849	893
1	238	268	298	328	357	387	417	447	476	506	536	566	596
	40	45	50	55	60	65	70	75	80	85	90	95	100

MATERIAL DENSITY (LBS PER CU. FT.)

1) Locate Material Weight per Cubic Foot at the bottom of the desired chart.

NOTE: If the weight per cubic foot is not known, weigh one gallon of material and multiply by 7.5. This will give your approximate material weight per cubic foot.

(5 gal. X 1.5 = Approx. 1 cubic foot)

2) Look up the column vertically to find the amount of Material you want to Spread per Acre.

3) Move left across the row to locate the Gate Setting required for your application.

CAUTION: This Chart is CORRECT only for the specific type of spreader noted at the top of this chart, and for the application rate (High or Low) and swath as noted.



RATE CHARTS

Liberty Pull-Type

18" MESH CHAIN RATE CHART 80 / 60



APPLICATION RATE 18" MESH CHAIN

470 Wayside St. S.
Cornelia, GA 30531
Ph: (706) 778-2767
Fax: (706) 778-2787

Low Application Rate

High Application Rate

Sprocket Ratio - 11:60

Spread Swath **80 ft**

Sprocket Ratio - 26:45

Spread Swath **60 ft**

12	340	383	425	468	510	553	595	638	680	723	765	808	850
11.5	326	367	407	448	489	530	570	611	652	693	733	774	815
11	312	351	390	429	468	507	546	585	624	663	702	741	779
10.5	298	335	372	409	446	484	521	558	595	632	670	707	744
10	283	319	354	390	425	461	496	531	567	602	638	673	709
9.5	269	303	337	370	404	438	471	505	539	572	606	640	673
9	255	287	319	351	383	415	446	478	510	542	574	606	638
8.5	241	271	301	331	361	392	422	452	482	512	542	572	602
8	227	255	283	312	340	368	397	425	454	482	510	539	567
7.5	213	239	266	292	319	345	372	399	425	452	478	505	531
7	198	223	248	273	298	322	347	372	397	422	446	471	496
6.5	184	207	230	253	276	299	322	345	368	392	415	438	461
6	170	191	213	234	255	276	298	319	340	361	383	404	425
5.5	156	175	195	214	234	253	273	292	312	331	351	370	390
5	142	159	177	195	213	230	248	266	283	301	319	337	354
4.5	128	143	159	175	191	207	223	239	255	271	287	303	319
4	113	128	142	156	170	184	198	213	227	241	255	269	283
3.5	99	112	124	136	149	161	174	186	198	211	223	236	248
3	85	96	106	117	128	138	149	159	170	181	191	202	213
2.5	71	80	89	97	106	115	124	133	142	151	159	168	177
2	57	64	71	78	85	92	99	106	113	120	128	135	142
1.5	43	48	53	58	64	69	74	80	85	90	96	101	106
1	28	32	35	39	43	46	50	53	57	60	64	67	71
	40	45	50	55	60	65	70	75	80	85	90	95	100

12	1429	1608	1787	1965	2144	2323	2501	2680	2859	3037	3216	3394	3573
11.5	1370	1541	1712	1883	2055	2226	2397	2568	2739	2911	3082	3253	3424
11	1310	1474	1638	1801	1965	2129	2293	2457	2620	2784	2948	3112	3275
10.5	1251	1407	1563	1720	1876	2032	2189	2345	2501	2658	2814	2970	3127
10	1191	1340	1489	1638	1787	1935	2084	2233	2382	2531	2680	2829	2978
9.5	1131	1273	1414	1556	1697	1839	1980	2122	2263	2404	2546	2687	2829
9	1072	1206	1340	1474	1608	1742	1876	2010	2144	2278	2412	2546	2680
8.5	1012	1139	1265	1392	1519	1645	1772	1898	2025	2151	2278	2404	2531
8	953	1072	1191	1310	1429	1548	1667	1787	1906	2025	2144	2263	2382
7.5	893	1005	1117	1228	1340	1452	1563	1675	1787	1898	2010	2122	2233
7	834	938	1042	1146	1251	1355	1459	1563	1667	1772	1876	1980	2084
6.5	774	871	968	1064	1161	1258	1355	1452	1548	1645	1742	1839	1935
6	715	804	893	983	1072	1161	1251	1340	1429	1519	1608	1697	1787
5.5	655	737	819	901	983	1064	1146	1228	1310	1392	1474	1556	1638
5	596	670	744	819	893	968	1042	1117	1191	1265	1340	1414	1489
4.5	536	603	670	737	804	871	938	1005	1072	1139	1206	1273	1340
4	476	536	596	655	715	774	834	893	953	1012	1072	1131	1191
3.5	417	469	521	573	625	677	730	782	834	886	938	990	1042
3	357	402	447	491	536	581	625	670	715	759	804	849	893
2.5	298	335	372	409	447	484	521	558	596	633	670	707	744
2	238	268	298	328	357	387	417	447	476	506	536	566	596
1.5	179	201	223	246	268	290	313	335	357	380	402	424	447
1	119	134	149	164	179	194	208	223	238	253	268	283	298
	40	45	50	55	60	65	70	75	80	85	90	95	100

1) Locate Material Weight per Cubic Foot at the bottom of the desired chart.

NOTE: If the weight per cubic foot is not known, weigh one gallon of material and multiply by 7.5. This will give your approximate material weight per cubic foot.
(5 gal. X 1.5 = Approx. 1 cubic foot)

2) Look up the column vertically to find the amount of Material you want to Spread per Acre.

3) Move left across the row to locate the Gate Setting required for your application.

CAUTION: This Chart is CORRECT only for the specific type of spreader noted at the top of this chart, and for the application rate (High or Low) and swath as noted.



RATE CHARTS

Liberty Pull-Type

20" MESH CHAIN RATE CHART 60 / 30



APPLICATION RATE 20" MESH CHAIN

470 Wayside St. S.
Cornelia, GA 30531
Ph: (706) 778-2767
Fax: (706) 778-2787

Low Application Rate

High Application Rate

Sprocket Ratio - 11:60

Spread Swath **60 ft**

Sprocket Ratio - 26:45

Spread Swath **30 ft**

12	515	579	644	708	772	837	901	965	1030	1094	1158	1223	1287
11.5	493	555	617	678	740	802	863	925	987	1048	1110	1172	1233
11	472	531	590	649	708	767	826	885	944	1003	1062	1121	1180
10.5	450	507	563	619	676	732	788	845	901	957	1014	1070	1126
10	429	483	536	590	644	697	751	804	858	912	965	1019	1073
9.5	408	458	509	560	611	662	713	764	815	866	917	968	1019
9	386	434	483	531	579	627	676	724	772	820	869	917	965
8.5	365	410	456	501	547	593	638	684	729	775	820	866	912
8	343	386	429	472	515	558	601	644	686	729	772	815	858
7.5	322	362	402	442	483	523	563	603	644	684	724	764	804
7	300	338	375	413	450	488	526	563	601	638	676	713	751
6.5	279	314	349	383	418	453	488	523	558	593	627	662	697
6	257	290	322	354	386	418	450	483	515	547	579	611	644
5.5	236	265	295	324	354	383	413	442	472	501	531	560	590
5	215	241	268	295	322	349	375	402	429	456	483	509	536
4.5	193	217	241	265	290	314	338	362	386	410	434	458	483
4	172	193	215	236	257	279	300	322	343	365	386	408	429
3.5	150	169	188	206	225	244	263	282	300	319	338	357	375
3	129	145	161	177	193	209	225	241	257	273	290	306	322
2.5	107	121	134	147	161	174	188	201	215	228	241	255	268
2	86	97	107	118	129	139	150	161	172	182	193	204	215
1.5	64	72	80	88	97	105	113	121	129	137	145	153	161
1	43	48	54	59	64	70	75	80	86	91	97	102	107
	40	45	50	55	60	65	70	75	80	85	90	95	100

MATERIAL DENSITY (LBS PER CU. FT.)

12	3245	3650	4056	4462	4867	5273	5678	6084	6490	6895	7301	7706	8112
11.5	3110	3498	3887	4276	4664	5053	5442	5831	6219	6608	6997	7385	7774
11	2974	3346	3718	4090	4462	4833	5205	5577	5949	6321	6692	7064	7436
10.5	2839	3194	3549	3904	4259	4614	4969	5324	5678	6033	6388	6743	7098
10	2704	3042	3380	3718	4056	4394	4732	5070	5408	5746	6084	6422	6760
9.5	2569	2890	3211	3532	3853	4174	4495	4817	5138	5459	5780	6101	6422
9	2434	2738	3042	3346	3650	3955	4259	4563	4867	5171	5476	5780	6084
8.5	2298	2586	2873	3160	3448	3735	4022	4310	4597	4884	5171	5459	5746
8	2163	2434	2704	2974	3245	3515	3786	4056	4326	4597	4867	5138	5408
7.5	2028	2282	2535	2789	3042	3296	3549	3803	4056	4310	4563	4817	5070
7	1893	2129	2366	2603	2839	3076	3312	3549	3786	4022	4259	4495	4732
6.5	1758	1977	2197	2417	2636	2856	3076	3296	3515	3735	3955	4174	4394
6	1622	1825	2028	2231	2434	2636	2839	3042	3245	3448	3650	3853	4056
5.5	1487	1673	1859	2045	2231	2417	2603	2789	2974	3160	3346	3532	3718
5	1352	1521	1690	1859	2028	2197	2366	2535	2704	2873	3042	3211	3380
4.5	1217	1369	1521	1673	1825	1977	2129	2282	2434	2586	2738	2890	3042
4	1082	1217	1352	1487	1622	1758	1893	2028	2163	2298	2434	2569	2704
3.5	946	1065	1183	1301	1420	1538	1656	1775	1893	2011	2129	2248	2366
3	811	913	1014	1115	1217	1318	1420	1521	1622	1724	1825	1927	2028
2.5	676	761	845	930	1014	1099	1183	1268	1352	1437	1521	1606	1690
2	541	608	676	744	811	879	946	1014	1082	1149	1217	1284	1352
1.5	406	456	507	558	608	659	710	761	811	862	913	963	1014
1	270	304	338	372	406	439	473	507	541	575	608	642	676
	40	45	50	55	60	65	70	75	80	85	90	95	100

MATERIAL DENSITY (LBS PER CU. FT.)

1) Locate Material Weight per Cubic Foot at the bottom of the desired chart.

NOTE: If the weight per cubic foot is not known, weigh one gallon of material and multiply by 7.5. This will give your approximate material weight per cubic foot.

(5 gal. X 1.5 = Approx. 1 cubic foot)

2) Look up the column vertically to find the amount of Material you want to Spread per Acre.

3) Move left across the row to locate the Gate Setting required for your application.

CAUTION: This Chart is CORRECT only for the specific type of spreader noted at the top of this chart, and for the application rate (High or Low) and swath as noted.



RATE CHARTS

Liberty Pull-Type

20" MESH CHAIN RATE CHART 80 / 60



APPLICATION RATE 20" MESH CHAIN

470 Wayside St. S.
Cornelia, GA 30531
Ph: (706) 778-2767
Fax: (706) 778-2787

Low Application Rate

High Application Rate

Sprocket Ratio - 11:60

Spread Swath **80 ft**

Sprocket Ratio - 26:45

Spread Swath **60 ft**

GATE SETTING	12	386	434	483	531	579	627	676	724	772	820	869	917	965
	11.5	370	416	463	509	555	601	648	694	740	786	833	879	925
	11	354	398	442	487	531	575	619	664	708	752	796	841	885
	10.5	338	380	422	465	507	549	591	633	676	718	760	802	845
	10	322	362	402	442	483	523	563	603	644	684	724	764	804
	9.5	306	344	382	420	458	497	535	573	611	650	688	726	764
	9	290	326	362	398	434	471	507	543	579	615	652	688	724
	8.5	273	308	342	376	410	444	479	513	547	581	615	650	684
	8	257	290	322	354	386	418	450	483	515	547	579	611	644
	7.5	241	271	302	332	362	392	422	452	483	513	543	573	603
	7	225	253	282	310	338	366	394	422	450	479	507	535	563
	6.5	209	235	261	288	314	340	366	392	418	444	471	497	523
	6	193	217	241	265	290	314	338	362	386	410	434	458	483
5.5	177	199	221	243	265	288	310	332	354	376	398	420	442	
5	161	181	201	221	241	261	282	302	322	342	362	382	402	
4.5	145	163	181	199	217	235	253	271	290	308	326	344	362	
4	129	145	161	177	193	209	225	241	257	273	290	306	322	
3.5	113	127	141	155	169	183	197	211	225	239	253	267	282	
3	97	109	121	133	145	157	169	181	193	205	217	229	241	
2.5	80	90	101	111	121	131	141	151	161	171	181	191	201	
2	64	72	80	88	97	105	113	121	129	137	145	153	161	
1.5	48	54	60	66	72	78	84	90	97	103	109	115	121	
1	32	36	40	44	48	52	56	60	64	68	72	76	80	
		40	45	50	55	60	65	70	75	80	85	90	95	100

MATERIAL DENSITY (LBS PER CU. FT.)

GATE SETTING	12	1622	1825	2028	2231	2434	2636	2839	3042	3245	3448	3650	3853	4056
	11.5	1555	1749	1944	2138	2332	2527	2721	2915	3110	3304	3498	3693	3887
	11	1487	1673	1859	2045	2231	2417	2603	2789	2974	3160	3346	3532	3718
	10.5	1420	1597	1775	1952	2129	2307	2484	2662	2839	3017	3194	3372	3549
	10	1352	1521	1690	1859	2028	2197	2366	2535	2704	2873	3042	3211	3380
	9.5	1284	1445	1606	1766	1927	2087	2248	2408	2569	2729	2890	3050	3211
	9	1217	1369	1521	1673	1825	1977	2129	2282	2434	2586	2738	2890	3042
	8.5	1149	1293	1437	1580	1724	1867	2011	2155	2298	2442	2586	2729	2873
	8	1082	1217	1352	1487	1622	1758	1893	2028	2163	2298	2434	2569	2704
	7.5	1014	1141	1268	1394	1521	1648	1775	1901	2028	2155	2282	2408	2535
	7	946	1065	1183	1301	1420	1538	1656	1775	1893	2011	2129	2248	2366
	6.5	879	989	1099	1208	1318	1428	1538	1648	1758	1867	1977	2087	2197
	6	811	913	1014	1115	1217	1318	1420	1521	1622	1724	1825	1927	2028
5.5	744	837	930	1022	1115	1208	1301	1394	1487	1580	1673	1766	1859	
5	676	761	845	930	1014	1099	1183	1268	1352	1437	1521	1606	1690	
4.5	608	684	761	837	913	989	1065	1141	1217	1293	1369	1445	1521	
4	541	608	676	744	811	879	946	1014	1082	1149	1217	1284	1352	
3.5	473	532	592	651	710	769	828	887	946	1006	1065	1124	1183	
3	406	456	507	558	608	659	710	761	811	862	913	963	1014	
2.5	338	380	423	465	507	549	592	634	676	718	761	803	845	
2	270	304	338	372	406	439	473	507	541	575	608	642	676	
1.5	203	228	254	279	304	330	355	380	406	431	456	482	507	
1	135	152	169	186	203	220	237	254	270	287	304	321	338	
		40	45	50	55	60	65	70	75	80	85	90	95	100

MATERIAL DENSITY (LBS PER CU. FT.)

1) Locate Material Weight per Cubic Foot at the bottom of the desired chart.

NOTE: If the weight per cubic foot is not known, weigh one gallon of material and multiply by 7.5. This will give your approximate material weight per cubic foot.

(5 gal. X 1.5 = Approx. 1 cubic foot)

2) Look up the column vertically to find the amount of Material you want to Spread per Acre.

3) Move left across the row to locate the Gate Setting required for your application.

CAUTION: This Chart is CORRECT only for the specific type of spreader noted at the top of this chart, and for the application rate (High or Low) and swath as noted.



RATE CHARTS

Liberty Pull-Type

24" BAR CHAIN 6 TOOTH 88K RATE CHART 60 / 30



APPLICATION RATE
24" BAR CHAIN 6 TOOTH 88K

470 Wayside St. S.
Cornelia, GA 30531
Ph: (706) 778-2767
Fax: (706) 778-2787

Low Application Rate

Sprocket Ratio - 11:60 Spread Swath **60** ft

12	734	826	918	1010	1102	1193	1285	1377	1469	1561	1652	1744	1836
11.5	704	792	880	968	1056	1144	1232	1320	1408	1496	1584	1672	1759
11	673	757	841	926	1010	1094	1178	1262	1346	1431	1515	1599	1683
10.5	643	723	803	884	964	1044	1125	1205	1285	1366	1446	1526	1606
10	612	688	765	841	918	994	1071	1147	1224	1300	1377	1453	1530
9.5	581	654	727	799	872	945	1017	1090	1163	1235	1308	1381	1453
9	551	620	688	757	826	895	964	1033	1102	1170	1239	1308	1377
8.5	520	585	650	715	780	845	910	975	1040	1105	1170	1235	1300
8	490	551	612	673	734	796	857	918	979	1040	1102	1163	1224
7.5	459	516	574	631	688	746	803	861	918	975	1033	1090	1147
7	428	482	535	589	643	696	750	803	857	910	964	1017	1071
6.5	398	448	497	547	597	646	696	746	796	845	895	945	994
6	367	413	459	505	551	597	643	688	734	780	826	872	918
5.5	337	379	421	463	505	547	589	631	673	715	757	799	841
5	306	344	382	421	459	497	535	574	612	650	688	727	765
4.5	275	310	344	379	413	448	482	516	551	585	620	654	688
4	245	275	306	337	367	398	428	459	490	520	551	581	612
3.5	214	241	268	295	321	348	375	402	428	455	482	509	535
3	184	207	229	252	275	298	321	344	367	390	413	436	459
2.5	153	172	191	210	229	249	268	287	306	325	344	363	382
2	122	138	153	168	184	199	214	229	245	260	275	291	306
1.5	92	103	115	126	138	149	161	172	184	195	207	218	229
1	61	69	76	84	92	99	107	115	122	130	138	145	153

MATERIAL DENSITY (LBS PER CU. FT.)

High Application Rate

Sprocket Ratio - 26:45 Spread Swath **30** ft

12	4629	5208	5786	6365	6943	7522	8101	8679	9258	9836	10415	10994	11572
11.5	4436	4991	5545	6100	6654	7209	7763	8318	8872	9427	9981	10536	11090
11	4243	4774	5304	5834	6365	6895	7426	7956	8486	9017	9547	10078	10608
10.5	4050	4557	5063	5569	6075	6582	7088	7594	8101	8607	9113	9619	10126
10	3857	4340	4822	5304	5786	6268	6751	7233	7715	8197	8679	9161	9644
9.5	3665	4123	4581	5039	5497	5955	6413	6871	7329	7787	8245	8703	9161
9	3472	3906	4340	4774	5208	5641	6075	6509	6943	7377	7811	8245	8679
8.5	3279	3689	4099	4508	4918	5328	5738	6148	6558	6967	7377	7787	8197
8	3086	3472	3857	4243	4629	5015	5400	5786	6172	6558	6943	7329	7715
7.5	2893	3255	3616	3978	4340	4701	5063	5425	5786	6148	6509	6871	7233
7	2700	3038	3375	3713	4050	4388	4725	5063	5400	5738	6075	6413	6751
6.5	2507	2821	3134	3448	3761	4074	4388	4701	5015	5328	5641	5955	6268
6	2314	2604	2893	3182	3472	3761	4050	4340	4629	4918	5208	5497	5786
5.5	2122	2387	2652	2917	3182	3448	3713	3978	4243	4508	4774	5039	5304
5	1929	2170	2411	2652	2893	3134	3375	3616	3857	4099	4340	4581	4822
4.5	1736	1953	2170	2387	2604	2821	3038	3255	3472	3689	3906	4123	4340
4	1543	1736	1929	2122	2314	2507	2700	2893	3086	3279	3472	3665	3857
3.5	1350	1519	1688	1856	2025	2194	2363	2531	2700	2869	3038	3206	3375
3	1157	1302	1447	1591	1736	1880	2025	2170	2314	2459	2604	2748	2893
2.5	964	1085	1205	1326	1447	1567	1688	1808	1929	2049	2170	2290	2411
2	771	868	964	1061	1157	1254	1350	1447	1543	1639	1736	1832	1929
1.5	579	651	723	796	868	940	1013	1085	1157	1230	1302	1374	1447
1	386	434	482	530	579	627	675	723	771	820	868	916	964

MATERIAL DENSITY (LBS PER CU. FT.)

1) Locate Material Weight per Cubic Foot at the bottom of the desired chart.

NOTE: If the weight per cubic foot is not known, weigh one gallon of material and multiply by 7.5. This will give your approximate material weight per cubic foot.
(5 gal. X 1.5 = Approx. 1 cubic foot)

2) Look up the column vertically to find the amount of **Material** you want to **Spread per Acre**.

3) Move left across the row to locate the **Gate Setting** required for your application.

CAUTION: This Chart is CORRECT only for the specific type of spreader noted at the top of this chart, and for the application rate (High or Low) and swath as noted.

RATE CHARTS

Liberty Pull-Type

24" BAR CHAIN 6 TOOTH 88K RATE CHART 80 / 60



APPLICATION RATE 24" BAR CHAIN 6 TOOTH 88K

470 Wayside St. S.
Cornelia, GA 30531
Ph: (706) 778-2767
Fax: (706) 778-2787

Low Application Rate

High Application Rate

Sprocket Ratio - 11:60

Spread Swath **80 ft**

Sprocket Ratio - 26:45

Spread Swath **60 ft**

12	551	620	688	757	826	895	964	1033	1102	1170	1239	1308	1377
11.5	528	594	660	726	792	858	924	990	1056	1122	1188	1254	1320
11	505	568	631	694	757	820	884	947	1010	1073	1136	1199	1262
10.5	482	542	602	663	723	783	843	904	964	1024	1084	1145	1205
10	459	516	574	631	688	746	803	861	918	975	1033	1090	1147
9.5	436	491	545	600	654	709	763	818	872	927	981	1036	1090
9	413	465	516	568	620	671	723	775	826	878	929	981	1033
8.5	390	439	488	536	585	634	683	732	780	829	878	927	975
8	367	413	459	505	551	597	643	688	734	780	826	872	918
7.5	344	387	430	473	516	559	602	645	688	732	775	818	861
7	321	361	402	442	482	522	562	602	643	683	723	763	803
6.5	298	336	373	410	448	485	522	559	597	634	671	709	746
6	275	310	344	379	413	448	482	516	551	585	620	654	688
5.5	252	284	316	347	379	410	442	473	505	536	568	600	631
5	229	258	287	316	344	373	402	430	459	488	516	545	574
4.5	207	232	258	284	310	336	361	387	413	439	465	491	516
4	184	207	229	252	275	298	321	344	367	390	413	436	459
3.5	161	181	201	221	241	261	281	301	321	341	361	382	402
3	138	155	172	189	207	224	241	258	275	293	310	327	344
2.5	115	129	143	158	172	186	201	215	229	244	258	273	287
2	92	103	115	126	138	149	161	172	184	195	207	218	229
1.5	69	77	86	95	103	112	120	129	138	146	155	164	172
1	46	52	57	63	69	75	80	86	92	98	103	109	115
	40	45	50	55	60	65	70	75	80	85	90	95	100

MATERIAL DENSITY (LBS PER CU. FT.)

12	2314	2604	2893	3182	3472	3761	4050	4340	4629	4918	5208	5497	5786
11.5	2218	2495	2773	3050	3327	3604	3882	4159	4436	4713	4991	5268	5545
11	2122	2387	2652	2917	3182	3448	3713	3978	4243	4508	4774	5039	5304
10.5	2025	2278	2531	2785	3038	3291	3544	3797	4050	4303	4557	4810	5063
10	1929	2170	2411	2652	2893	3134	3375	3616	3857	4099	4340	4581	4822
9.5	1832	2061	2290	2519	2748	2977	3206	3436	3665	3894	4123	4352	4581
9	1736	1953	2170	2387	2604	2821	3038	3255	3472	3689	3906	4123	4340
8.5	1639	1844	2049	2254	2459	2664	2869	3074	3279	3484	3689	3894	4099
8	1543	1736	1929	2122	2314	2507	2700	2893	3086	3279	3472	3665	3857
7.5	1447	1627	1808	1989	2170	2351	2531	2712	2893	3074	3255	3436	3616
7	1350	1519	1688	1856	2025	2194	2363	2531	2700	2869	3038	3206	3375
6.5	1254	1410	1567	1724	1880	2037	2194	2351	2507	2664	2821	2977	3134
6	1157	1302	1447	1591	1736	1880	2025	2170	2314	2459	2604	2748	2893
5.5	1061	1193	1326	1459	1591	1724	1856	1989	2122	2254	2387	2519	2652
5	964	1085	1205	1326	1447	1567	1688	1808	1929	2049	2170	2290	2411
4.5	868	976	1085	1193	1302	1410	1519	1627	1736	1844	1953	2061	2170
4	771	868	964	1061	1157	1254	1350	1447	1543	1639	1736	1832	1929
3.5	675	759	844	928	1013	1097	1181	1266	1350	1434	1519	1603	1688
3	579	651	723	796	868	940	1013	1085	1157	1230	1302	1374	1447
2.5	482	542	603	663	723	784	844	904	964	1025	1085	1145	1205
2	386	434	482	530	579	627	675	723	771	820	868	916	964
1.5	289	325	362	398	434	470	506	542	579	615	651	687	723
1	193	217	241	265	289	313	338	362	386	410	434	458	482
	40	45	50	55	60	65	70	75	80	85	90	95	100

MATERIAL DENSITY (LBS PER CU. FT.)

1) Locate Material Weight per Cubic Foot at the bottom of the desired chart.

NOTE: If the weight per cubic foot is not known, weigh one gallon of material and multiply by 7.5. This will give you your approximate material weight per cubic foot.

(5 gal. X 1.5 = Approx. 1 cubic foot)

2) Look up the column vertically to find the amount of Material you want to Spread per Acre.

3) Move left across the row to locate the Gate Setting required for your application.

CAUTION: This Chart is CORRECT only for the specific type of spreader noted at the top of this chart, and for the application rate (High or Low) and swath as noted.

